

SCHEMATIC AND SERVICE INFORMATION FOR

HOWARD RADIO COMPANY

MODELS 435, 436 and 437

SHORT WAVE RECEIVER

HOLLAND

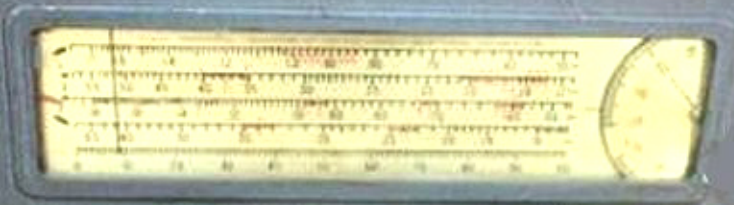

CRYSTAL PHASE



RANGE



MAIN TUNING



A.F. GAIN



SOUNDHEAD



OFF PITCH



A.F. GAIN



HOWARD RADIO CO.

MODEL 435

MODEL 436

MODEL 437

MODELS—435-436-437 "PROGRESSIVE SERIES"

TYPE 3-820 EXTERNAL SPEAKER is designed especially for use with Howard Communications Receivers. The input impedance is of the correct value to perfectly match the output transformer of Models 435, 436, 437, and 460. The speaker unit consists of a heavy duty high efficiency permanent magnet, 8" dynamic speaker mounted in an acoustically treated (felt lined) welded steel cabinet finished in fine suede wrinkle, supplied with a 5 ft. spade terminal cable.

(NOTE:- The Progressive Series 435, 436, 437, is based on the Model 435 receiver. The 436 is the 435 circuit with the addition of the noise silencer and additional features. The progressive additions to the original 435 circuit may include: 605 Carrier Level Meter, 3-820 External Speaker, 650 Pre-Selector, 660 Frequency Monitor, 655 Loop Kit, and 610 Power Pack. For data on these, SEE INDEX).

TYPE 610 "B" POWER PACK. For conversion of 6 Volts d.c. to 300 Volts d.c. for operation of Howard Models 435, 436, and 437 Communications Receivers from 6 Volt Storage Battery, the Type 610 Power Pack is a convenient and practical converter. A four prong plug fits the socket on Model 435, 436, and 437 Receivers, carrying both A and B power to the set. Only two connections from the Power Pack to the storage battery are required. Ample length of cable is provided. Battery current drawn for Model 435 is 6.6 amps; for Model 436 is 6.9 amps; and Model 437 is 7.75 amps. ON and OFF Switch on Power Unit.

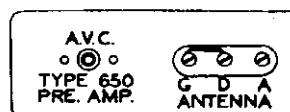
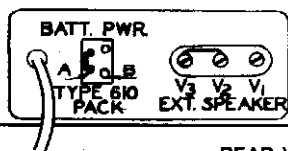

REAR VIEW OF CABINET

EXTERNAL CONNECTIONS

As we face the back of the receiver, the first terminal strip at the right coded G, D, A are of which V3 and V2 must be shorted when using the Antenna and Ground connections. For the conventional type of flat top antenna systems use of the Howard external speaker No. 3-820, leave the shorting wire between "G" and "D" and by removing the shorting wire and connecting connect Antenna to "A". Connect ground to "G". leads from the external permanent dynamic speaker to lugs V3 and V1.

If a doublet antenna is used, remove the jumper between G and D and attach doublet wires to D and A and a ground to "G".

We have found it inadvisable to recommend a definite length of antenna due to variable conditions. We do, however, suggest that you refer to the recommendations as given in the A. R. R. L. Antenna handbook.

The single terminal next to the antenna-ground strip is coded for use with the Howard Model 650 Pre-Amplifier,

ADAPTATION FOR BATTERY SUPPLY

When it is desired to use "A" and "B" batteries when the Howard 610 Power Pack is not available, connect as follows:

Remove the jumper from the battery power socket. Connect "B" 250 Volts to terminal marked "B" in diagram. Connect one side of the 6 Volt "A" supply to terminal marked "A". Connect the other side of the "A" supply and "B -" to the chassis ground terminal.

The "B" current required for Models 435 and 436 is 60 Mills. The "A" current requirement is 2.9 Amps. This includes the 605 Carrier Level Meter.

The "B" current required for Model 437 is 82 Mills. The "A" current requirement is 3.5 Amps, allowing for the 605 Carrier Level Meter.

MODEL 435
MODEL 436

HOWARD RADIO CO.

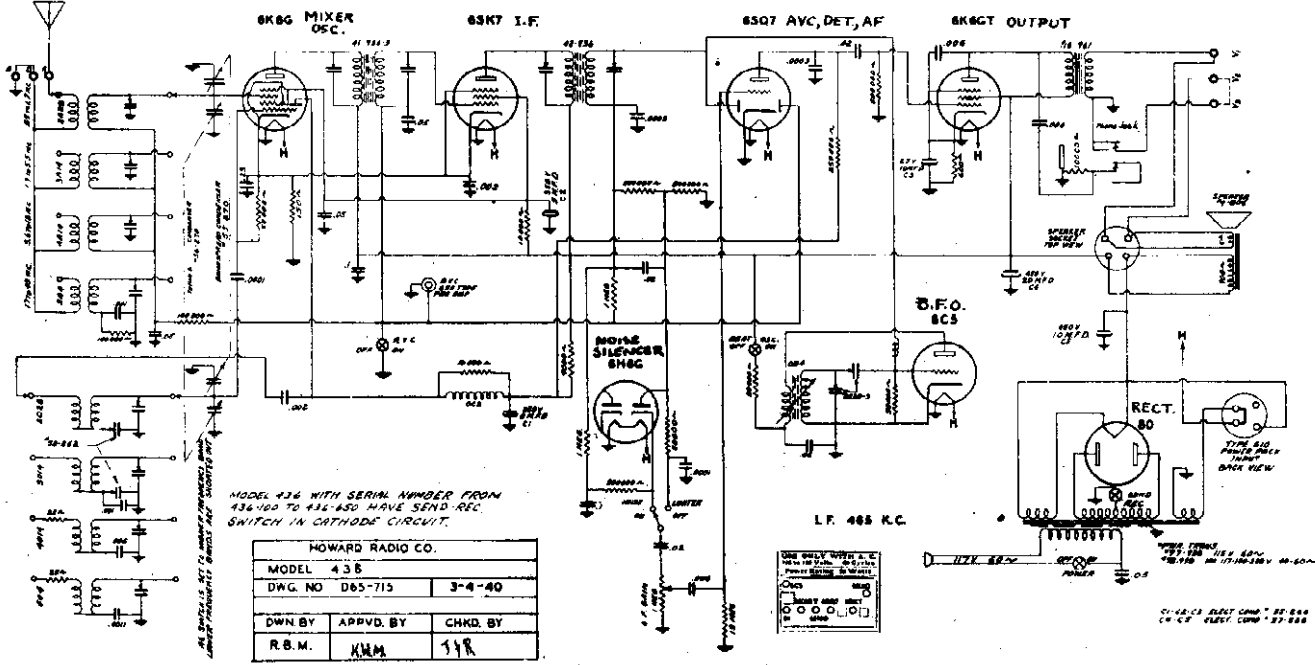
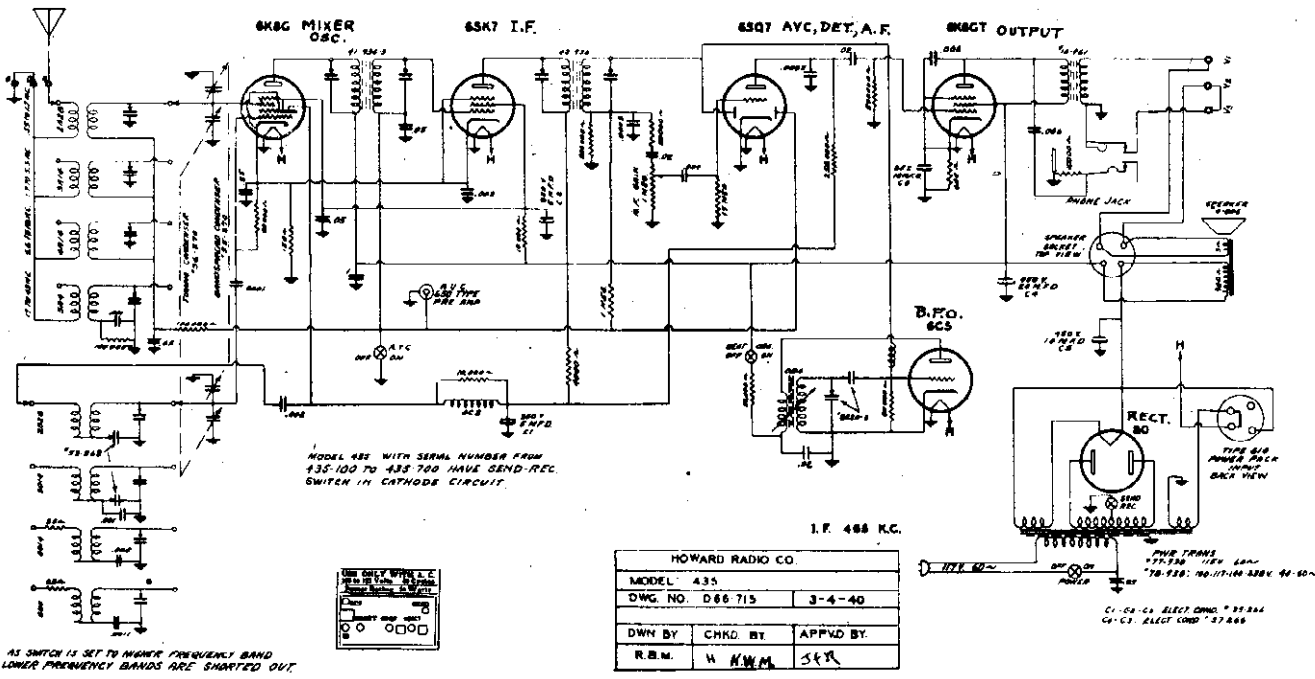

The following are the Engineering Specifications for Model 435,436.

POWER CONSUMPTION.50 Watts, 105-125 Volts, A.C. 60 Cycle

INTERMEDIATE FREQUENCY465 KC

FREQUENCY RANGE - Divided into four bands as follows:

.55 to 1.7 mc (545-176 meters)	5.6 to 18 mc (54-16.6 meters)
1.7 to 5.6 mc (176-54 meters)	17 to 43 mc (17-7 meters)

SPEAKER SYSTEM

Built-in 6½" Electro Dynamic
Connections provided for External
Speaker (Howard Type 3-820)

POWER OUTPUT

Type.Single 6K6G
Maximum2½ Watts

HOWARD RADIO CO.

MODEL 437

MODEL 660
(FREQUENCY MONITOR)

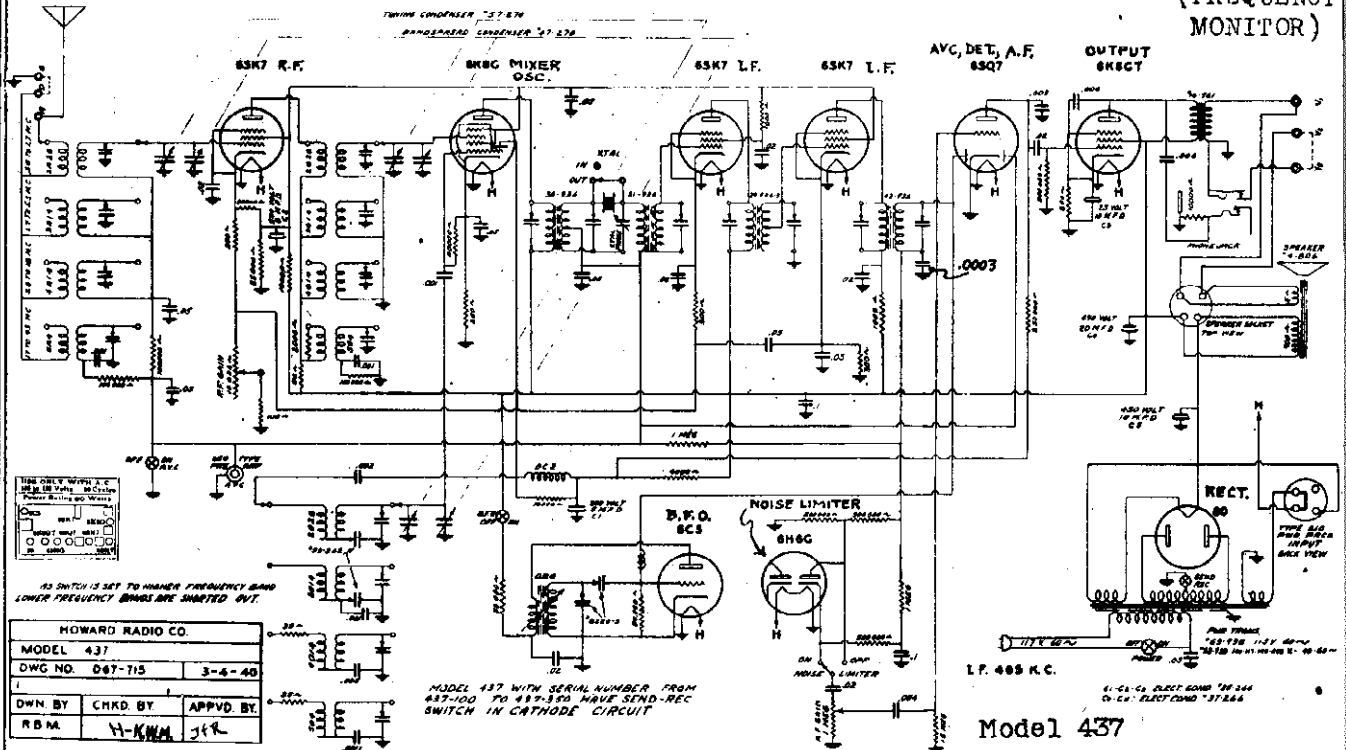

USE ONLY VACUUM TUBES LISTED IN THIS MANUAL. No Other Tubes Working on Waves.

AS SWITCH IS SET TO HIGHER FREQUENCY BAND LOWER FREQUENCY BANDS ARE SHORTED OUT.

HOWARD RADIO CO.		
MODEL 437		
DWG. NO. D47-715		3-6-49
DWN. BY	CHKD. BY	APPVD. BY
R.B.M.	H.K.M.	J.R.

MODEL 437 WITH SERIAL NUMBER FROM 437-100 TO 437-350 HAVE SEND-REC SWITCH IN CATHODE CIRCUIT

FREQUENCY RANGE - Divided into four bands as follows:

.55 to 1.7 mc (545-176 meters)
1.7 to 5.6 mc (176-54 meters)

5.6 to 18 mc (54-16.6 meters)
17 to 43 mc (17-7. meters)

POWER CONSUMPTION.60 Watts, 105-125 Volts, A.C. 60 Cycle

INTERMEDIATE FREQUENCY465 KC

SPEAKER SYSTEM

POWER OUTPUT

Built-in 6 1/2" Electro Dynamic
Connections provided for External
Speaker (Howard Type 3-820)

TypeSingle 6K6G
Maximum4 Watts

TYPE 660 FREQUENCY MONITOR

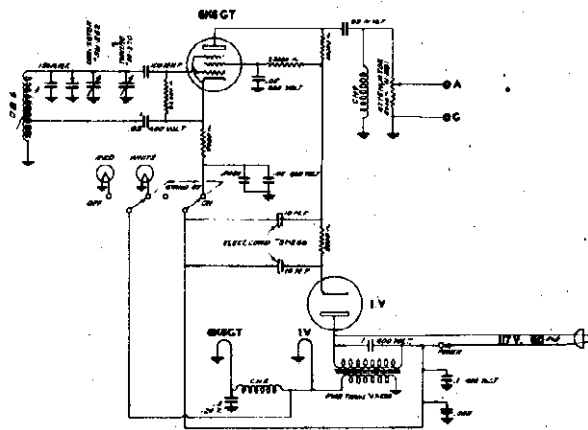

HOWARD RADIO CO.		
MODEL 660 FREQ MON.		
DWG. NO. D68-715		1-3-49
DWN. BY	CHKD. BY	APPVD. BY
R. B. M.	R. W. M.	J. R.

The Howard Frequency Monitor Model 660 consists of a highly stabilized oscillator covering the fundamental frequency range of 850 to 1030 kilocycles, harmonics of which are used as reference or measurement points on the higher bands. The R. F. Output of this oscillator is loosely coupled to the antenna circuit of the receiver, and the voltage applied to the receiver is controlled by a variable resistance attenuator.

The Oscillator is tuned by a precision ceramic insulated variable condenser carrying an extremely accurate frequency scale covering the 10, 20, 40, 80 and 160 meter amateur bands as well as the fundamental range. The range is so selected that harmonics cover the entire length of all amateur bands, and these are calibrated so that frequency can be read within one kilocycle on the lower frequency bands and five kilocycles on the highest band.

The Power Supply for this unit is self-contained, and is for use on 105-125 Volts, A.C. 40-60 Cycle. Available at other voltages and frequencies on special order.

MODEL 435
MODEL 436
MODEL 437

HOWARD RADIO CO.

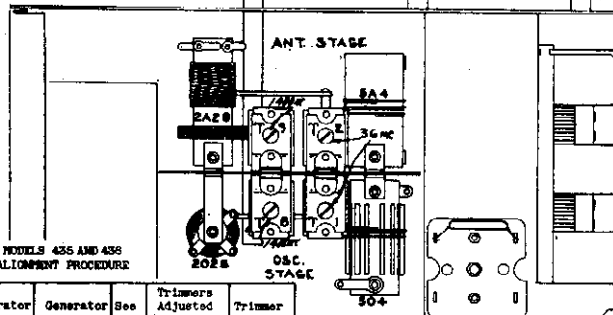
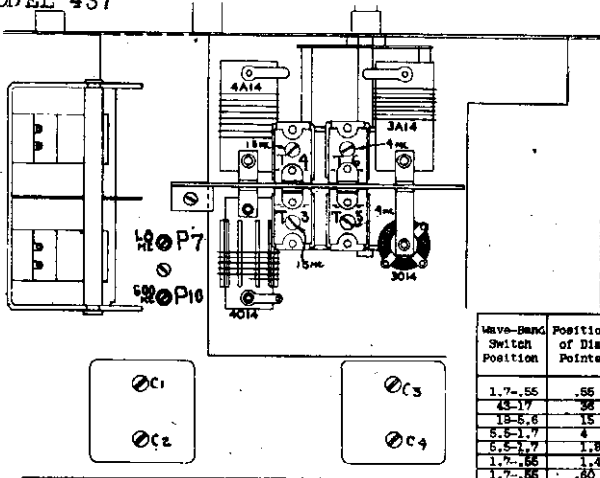

MODELS 435 AND 436
ALIGNMENT PROCEDURE

Wave-Band Switch Position	Position of Dial Pointer	Generator Frequency	Generator Connection	See Note	Trimms Adjusted (In order shown)	Trimmer Function
1.7-.55	.55	465 KC	Mixer Grid	1	C1, C2, C3, C4	IF
43-17	.36	36 KC	A and DO	2	T1, T2	Osc. Ant.
18-5.6	.15	15 KC	A and DO	3	T3, T4	Osc. Ant.
5.5-1.7	.4	4 KC	A and DO	3	T5, T6	Osc. Ant.
5.5-1.7	1.8	1.8 MC	A and DO	4	P7	Osc. Pad.
1.7-.55	1.4	1400 KC	A and DO	4	T8, T9	Osc. Ant.
1.7-.55	.80	600 KC	A and DO	4	P10	Osc. Pad.

The alignment is made with the BFO Off, the AVC Off, and the Band Spread set to 100.

The main dial hand must stop EXACTLY ON the last line at the end of the scale when the condenser is fully closed without force on the tuning control.

NOTE 1: After the alignment of the I.F. stages is completed, align the BFO system as follows:

1. Set pitch control 3 turns back from the "IN" position and turn on the BFO Switch.
2. Adjust the trimmer in the BFO can to obtain maximum sound which will be a hissing noise. Turn tuning knob to be sure this sound is not some tunable frequency that is causing it.
3. Check beats against some broadcast station to determine if the strength of the beat is normal.

NOTE 2: In this band (17 to 43 MC) only the oscillator follows the received signal 465 KC lower in frequency. Therefore when checking for the image, if the alignment has been made at 36 MC, it will be found at about 37 MC. This will determine if the alignment was correctly made at 36 MC.

NOTE 3: Check for image on all bands except the 17 to 43 MC band at a point 930 KC lower on the dial.

NOTE 4: Rock main dial slightly for point of maximum signal as the padding condenser is being adjusted.

MODELS 435 AND 436
SOCKET VOLTAGES

TUBE	FUNC-TION	CATH-ODE	SCR-GRID	PLATE	OSC. PLATE	TUBE	FUNC-TION	CATH-ODE	SCR-GRID	PLATE	OSC. PLATE
6X80	Mixer	3	100	195	170	6C5	BFO	14	195	180	
6SK7	I.F. Amp.	3	100	195		80	Rect.				High Voltage = 250 V.
6SQ7	Det.			70							Drop across Field = 55 V.

Readings from ground with 1000 Ohm per V. Meter
Line Voltage 117 V.
Main Filament Voltage 6.2 V.
Rectifier Filament Voltage 4.9 v.

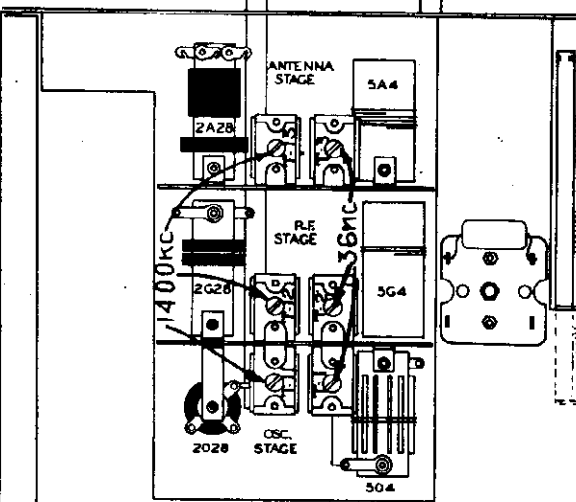
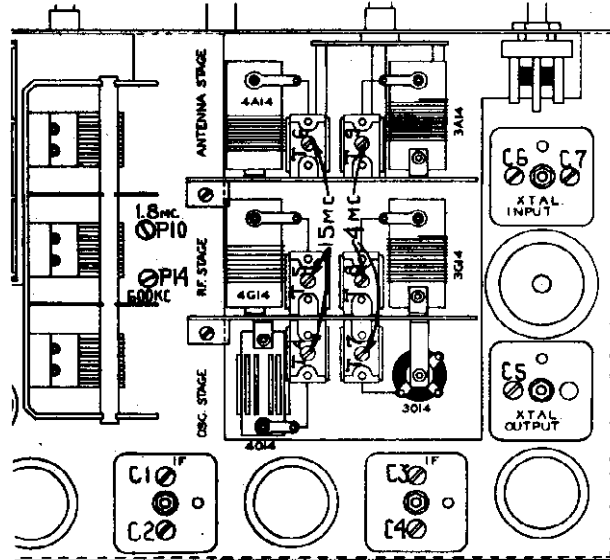

MODEL 437
ALIGNMENT PROCEDURE

Wave-Band Switch Position	Position of Dial Pointer	Generator Frequency	Generator Connection	See Note	Trimms Adjusted (In order shown)	Trimmer Function
1.7-.55	.55	465 KC	Mixer Grid	1	C1, C2, C3, C4	IF
43-17	.36	36 KC	A and DO	2	T1, T2	Osc. Ant.
18-5.6	.15	15 KC	A and DO	3	T3, T4	Osc. Ant.
5.5-1.7	.4	4 KC	A and DO	3	T5, T6	Osc. Ant.
5.5-1.7	1.8	1.8 MC	A and DO	4	P7	Osc. Pad.
1.7-.55	1.4	1400 KC	A and DO	4	T8, T9	Osc. Ant.
1.7-.55	.80	600 KC	A and DO	4	P10	Osc. Pad.

The alignment is made with the BFO Off, the AVC Off, and the Band Spread set to 100.

The main dial hand must stop EXACTLY ON the last line at the end of the scale when the condenser is fully closed without force on the tuning control.

NOTE 1: After the alignment of the I.F. stages is completed, align the BFO system as follows:

MODEL 437
SOCKET VOLTAGES

TUBE	FUNCTION	CATH-ODE	SCR-GRID	PLATE	OSC. PLATE	TUBE	FUNCTION	CATH-ODE	SCR-GRID	PLATE	OSC. PLATE
6SK7	RF	3	92	240		6SQ7	Det.			70	
6X80	Mixer	3	92	240		6AV6	Output	174	240	223	
6SK7	I.F. Amp.	3	92	240	200	6C5	BFO			75	
6SK7	I.F. Amp.	3	92	235		80	Rect.				High Voltage = 315V. Drop across Spkr. Field = 75 V.

R.F. Gain Pull On
Readings from ground with 1000 Ohm per V. Meter
Line Voltage 117 V.
Main Filament Voltage 6.2 V.
Rectifier Filament Voltage 5 V.

1. Set pitch control 3 turns back from the "IN" position and turn on the BFO Switch.
2. Adjust the trimmer in the BFO can to obtain maximum sound which will be a hissing noise. Turn tuning knob to be sure this sound is not some tunable frequency that is causing it.
3. Check beats against some broadcast station to determine if the strength of the beat is normal.

NOTE 2: In this band (17 to 43 MC) only the oscillator follows the received signal 465 KC lower in frequency. Therefore, when checking for the image, if the alignment has been made at 36 MC, it will be found at about 37 MC. This will determine if the alignment was correctly made at 36 MC.

NOTE 3: Check for image on all bands except the 17 to 43 MC band at a point 930 KC lower on the dial.

NOTE 4: Rock main dial slightly for point of maximum signal as the padding condenser is being adjusted.

HOWARD RADIO CO.

MODEL 435
 MODEL 436
 MODEL 437

TYPE 605 CARRIER LEVEL METER ADAPTABLE TO MODELS 435, 436, 437

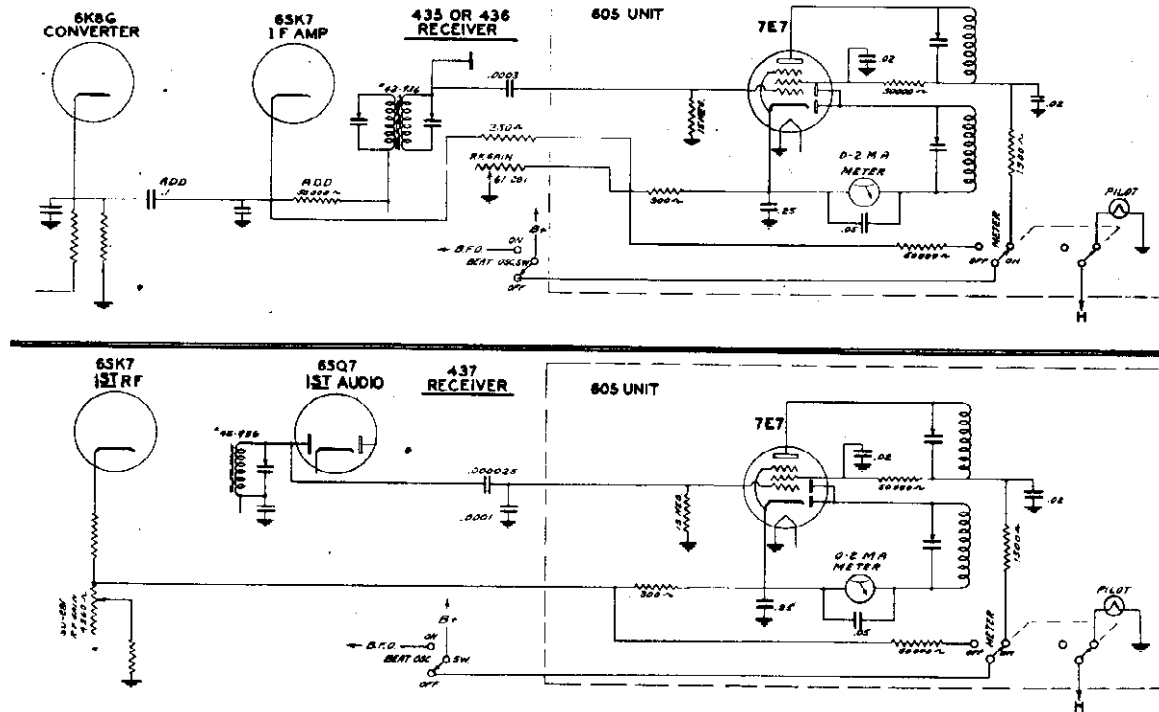

THE HOWARD CARRIER LEVEL METER gives an indication of the strength of the signal carrier in microvolts as delivered at the receiver.

The meter scale is calibrated from 0 to 50. When the meter set control (R. F. Gain) located directly below meter, is set exactly on the 50 division, the reading on the meter will be the actual microvolts delivered to the receiver.

Before using the carrier level meter, tune the signal to exact resonance with the meter switch in the OFF position, and adjust the R. F. GAIN CONTROL to a point where the signal is just audible. This will not throw the meter off scale when the meter switch is thrown to the ON position. Follow instructions given below.

- The AVC Switch must be ON.
- The Meter Switch must be ON.
- The BFO Switch must be OFF.

To avoid the possibility of introduced error, the BFO Switch is so connected that the meter is not in the circuit when the BFO Switch is in the ON position. Therefore the meter can be used only when the BFO Switch is in the OFF position.

The maximum deflection of meter pointer is the true indication of resonance in tuning. With a strong signal the meter will naturally be thrown off scale until the R. F. Control is rotated counter-clockwise. A point will be reached during this rotation where the meter hand is at 50. Then the input value in microvolts is read direct at the position of the pointer knob. For better accuracy this reading is multiplied by a correction factor as given on a separate chart to cover the various bands calibrated for each receiver.

MODEL 605		
DWC NO. 68-715	3-1-40	
DWN BY	CHCKD BY	APPVD BY
R.B.M.	K.W.M.	J+R.

