

National Co., The Inc.

Model: SW-54

Chassis:

Year: Pre 1952

Power:

Circuit:

IF:

Tubes:

Bands:

Resources

[Riders Volume 22 - NATIONAL 22-48](#)

[Riders Volume 22 - NATIONAL 22-49](#)

[Riders Volume 22 - NATIONAL 22-50](#)

[Riders Volume 22 - NATIONAL 22-51](#)

[Riders Volume 22 - NATIONAL 22-52](#)

[Riders Volume 22 - NATIONAL 22-53](#)

[Riders Volume 22 - NATIONAL 22-54](#)

[Riders Volume 22 - NATIONAL 22-55](#)

[Riders Volume 22 - NATIONAL 22-56](#)

[Riders Volume 22 - NATIONAL 22-57](#)

1-1. INSTALLATION PROCEDURE

The SW-54 Receiver is designed to operate from a 105/130 volt, 50/60 cycle, A.C. source of supply or a 105/130 volt, D.C. source of supply. Normal power consumption is approximately 25 watts at 115 volts.

Installation of the SW-54 is accomplished as follows:

1. Connect the antenna as recommended in Section 1-2.
2. Connect a good external ground (radiator or water pipe) to the cabinet. A screw-type terminal is provided at the top center of the cabinet back to facilitate this connection. This connection, if used, serves two purposes:
 - a. Achieves a considerable reduction in noise interference in certain localities.
 - b. Eliminates the possibility of shock occurring if the operator makes bodily contact between the Receiver and ground.
3. Connect the power cable and plug to the proper source of supply i.e., 105/130 volts, 50/60 cycles, A.C. or 105/130 volts D.C. Proper polarity of the plug should be observed when connection is made to a power source although no damage to the Receiver will occur if the polarity is reversed. Reversed polarity will be evidenced as follows and is corrected by simply reversing the plug prongs in the power outlet.
 - a. D.C. Power Source — The Receiver will be inoperative, although the tubes and pilot lamp will light.
 - b. A.C. Power Source — A hum may be heard in the output of the Receiver.

Proper polarization of the plug will eliminate the possibility of shock occurring in installations where one side of the power line is grounded, if the operator should make bodily contact between the Receiver and ground.
4. Adjust controls as recommended in Section 2 for the reception of signals.

1-2. ANTENNA RECOMMENDATIONS

The antenna input circuit of the SW-54 is arranged for operation from either a single-wire type, doublet type or other types of antennas having impedances of 70 ohms or more. The input impedance of the antenna circuit is approximately 300 ohms.

The most practical antenna for use in installations where the Receiver is to be used over a wide range of frequencies is the single-wire type. An antenna length of from 50 to 75 feet is recommended although the length is not critical and any length from 25 to 75 feet may be used. If the Receiver is to be operated on one frequency or a narrow band of frequencies, best results will be obtained by the use of a tuned antenna, such as the folded doublet or half-wave dipole type, designed for the operating frequency.

The methods of connecting the various types of antennas to the antenna terminal strip at the rear of the Receiver are as follows:

1. Single-wire type — Connect the antenna to terminal A at the left of the strip and connect the metal link to the unused A terminal.
2. Doublet-type — Connect the antenna feeders to the two terminals marked A; the metal link is not used.
3. Concentric transmission line type — Connect the inner conductor to terminal A at the left of the strip and the outer conductor to the other A terminal. Connect the metal link to the center A terminal.

2-1. GENERAL DESCRIPTION

The SW-54 is an A.C./D.C. superheterodyne Receiver having a complement of four tubes plus a rectifier with a continuous frequency range of from 540 kilocycles to 30 megacycles. The Receiver is designed to provide reception of amplitude modulated voice or music and code telegraphy signals throughout its entire frequency range.

A stage outline of the circuit employed in the Receiver is given below together with the tube type associated with each stage.

Converter	12BE6
C.W. Osc. -- I.F. Amplifier (455 Kc.)	12BA6
Second Det. - A.V.C. - First Audio	12AV6
Audio Output	50C5
Rectifier	35Z5

Two audio output circuits are provided in the SW-54:

1. The built-in loudspeaker is a permanent magnet type.
2. Phone tip jacks are mounted at the rear of the receiver to accommodate headphones. The headphones load impedance is not critical, permitting the use of various types of headphones including crystal types.

2-2. TUNING SYSTEM

The two-gang main tuning capacitor and four set of coils are used to cover the frequency range of the SW-54 in four tuning bands as shown on the following table. A bandsread tuning dial scale calibrated from 0 to 100 is provided to permit bandsread tuning of any portion of the frequency range of the receiver.

BAND	FREQUENCY COVERAGE
A	.54 to 1.6 mc.
B	1.6 to 4.7 mc.
C	4.6 to 14.5 mc.
D	12 to 30 mc.

The main dial has four scales accurately calibrated directly in megacycles. The respective scales are marked with heavy black scorings to clearly locate for the operator such short-wave features as the Amateur, Police, Foreign Broadcast and Ship bands. These locating markers are identified by letters AM, P, F and S respectively.

2-3. OPERATING INSTRUCTIONS

After the SW-54 has been installed as outlined in Section 1, it is placed in operation for voice

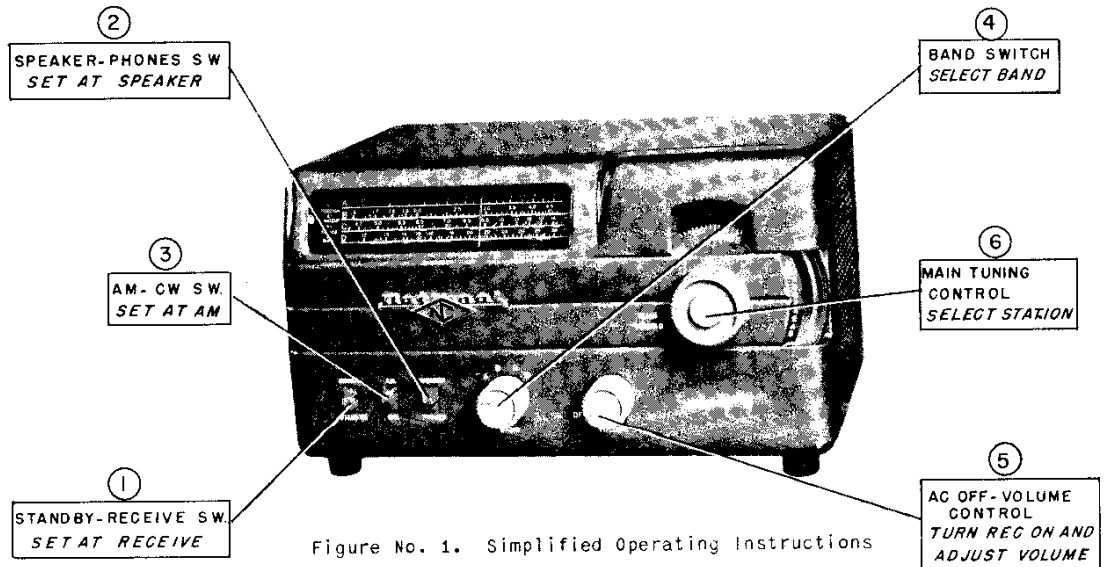

Figure No. 1. Simplified Operating Instructions

MODEL SW-54

or music reception by adjustment of the receiver controls. Figure No. 1 gives the step-by-step procedure to follow for the reception of signals. The same procedure is outlined below with a brief description of the function of each control.

1. Set the Standby-Receive switch at Receive. This switch, in the Standby position is used to quiet the Receiver for a period of time such as during a transmitting period, when it is desirable to resume reception immediately without waiting for the tubes to warm up.
2. Set the Speaker-Phones switch at Speaker. Should headphone operation be desired set the switch at Phones and connect headphones to the Phones jack located at the rear of the receiver.
3. Set the AM-CW switch at AM.
4. Set the Band switch at the band of frequencies to be tuned. The four positions of the Band switch select the proper set of coils to cover the frequency range of the four tuning bands of the SW-54. Each position is marked with a band letter designation which corresponds to the markings appearing on the main dial.
5. Turn the Volume control from the A.C. off position to the point providing the desired audio volume. In the A.C. Off position the SW-54 is turned off: advancing the control knob in a clockwise direction turns on the Receiver and increases the audio output volume to a maximum at the extreme clockwise position.
6. Set the main tuning dial pointer at the desired frequency. The main tuning control knob and dial scale are used to tune the entire frequency range of the Receiver and tunes at any one time the band of frequencies selected by the Band switch.
7. To utilize the advantages of bandsread (fine) tuning and logging provided by the SW-54 proceed as follows:

- (a) Set the main tuning dial pointer at the Low frequency limit of the band of frequencies to be tuned.
- (b) Hold the main tuning control knob (or the outer edge of the Bandsread dial) firmly enough to prevent the main tuning dial pointer from moving and set the bandsread dial at Zero by rotating the inner segment of the Bandsread dial.
- (c) Bandsread tuning can now be accomplished by rotation of the entire Bandsread dial in a clockwise direction. Logging of stations is accomplished by noting the frequency setting of the main dial pointer and the numerical setting of the bandsread dial.

2-4. CODE TELEGRAPHY RECEPTION

The adjustment of the receiver controls for code reception is the same as that for voice and music except that the AM-CW switch must be set at CW.

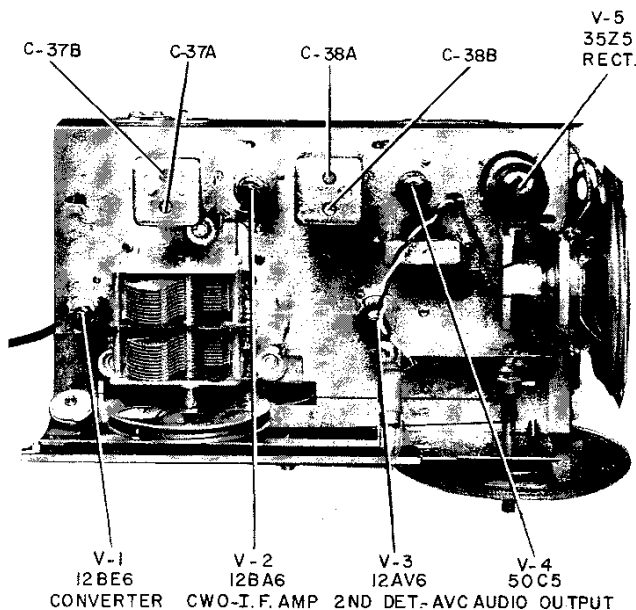

NOTE: ALTERNATE IF TRANS. HAVE L-9 & L-11 AT BOTTOM OF CAN, L-10 & L-12 AT THE TOP.

Figure No. 2. Tube and Alignment Adjustment Locations

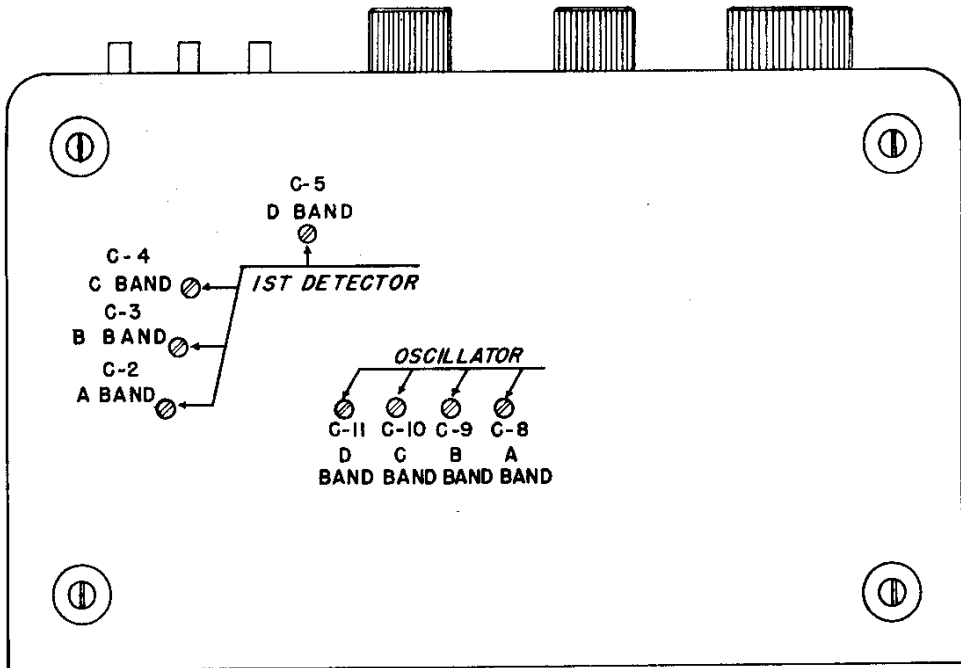
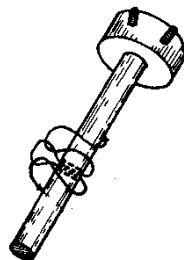
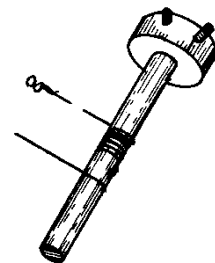

Figure No. 3. R.F. Alignment Trimmer Locations

1 LENGTH OF CORD = 36" INCLUDING CLIP AT ONE END AND LOOP IN OTHER.
 MEASURE 16 3/4" FROM CLIP END AND MARK THIS POINT.
 LOOP CORD AT MARK AND PUSH THRU HOLE IN SHAFT.
 BRING ENDS OF CORD THRU LOOP AS SHOWN AND PULL TAUT KEEPING MARKED POINT OVER HOLE.



2 a WIND CLIP END OF CORD 6 1/2 TURNS AROUND SHAFT AND WITH TUNING CAPACITOR AT MAXIMUM HOOK CLIP TO LARGE PULLEY.
 b TURN CAPACITOR TO MINIMUM ALLOWING OTHER END OF CORD TO WIND ITSELF AROUND SHAFT.



3 SET PULLEY AT POSITION SHOWN AND PASS CORD AROUND SMALL PULLEY. FASTEN SPRING TO END OF CORD AND CLIP TO HOLE IN PULLEY PROVIDING CORRECT TENSION.

4. ATTACH POINTER TO CORD AND BY ELECTRICAL CALIBRATION TEST SET POINTER AT CORRECT POSITION

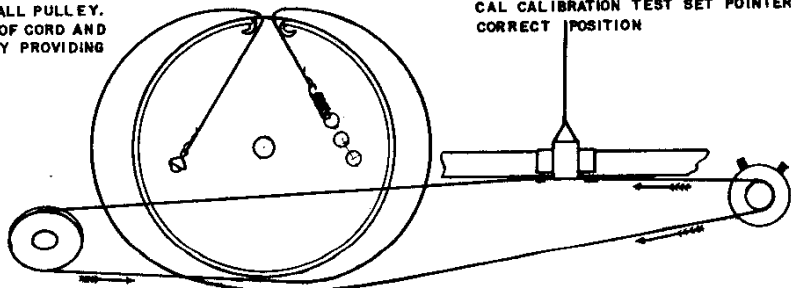

Figure No. 4. Dial Stringing Instructions

MODEL SW-54

SW-54

ALIGNMENT AND TEST INSTRUCTIONS

Note: 1. An isolation transformer should be used wherever possible: If the transformer is not available, the set may be handled with safety if the following precautions are observed:

- a. Find out with an AC volt meter which side of power socket is at ground potential.
 - b. With receiver plug out of power socket, turn on power switch and with an ohmmeter find which tab of power cord is connected directly to the chassis through the volume control switch. Insert the cord into the power socket so that both grounds come together. When these precautions have been taken one may connect other grounds to receiver chassis without danger. If the power source is DC, the set will not operate unless proper polarity of the plug is observed.
2. A dummy antenna of 300 ohms is also needed. Alignment should not be made without this resistor.
3. A blocking condenser .01 to .1 mfd. should be used. This condenser should be used in series with the hot lead of the signal source at all times. Having observed polarity of plug as under Note #1, the ground lead of the signal source may be connected directly to the chassis.

I Check tuning condenser and dial pointer setting--

- a. Rotate tuning dial fully counter-clockwise against stop.
- b. Look at tuning condenser. The rotor should be fully meshed. This is very, very important. This is your reference, and will avoid tracking and calibration troubles. When we say fully meshed, we do not mean 1/2 of a degree or one degree, but that the plates be flush.
- c. To set the condenser rotate dial fully counter-clockwise. Loosen the two set screws on dial shaft. Hold the collar, which has the two set screws, against the stop. Turn dial until tuning condenser hits its stop. Tighten set screws.
- d. Set the pointer over the first calibration mark on band "B".

II Connect the power to the receiver.

III Connect headphones and output meter to output jack.

IV Connect the 300 ohm dummy to hot antenna terminal.

V Put band change switch in the "A" position.

VI Set dial to 1000 kc.

VII Set signal to 455 kc \pm 1 kc.

Caution: Do not depend on the accuracy of your signal generator, unless you know it is good.

VIII Connect the signal source to the top contact on the front switch wafer (flue lead). This is the mixer grid connection with the band change switch at "A".

IX Adjust L9, 10, 11 and 12 or C-37A C37B, C38A and C38B for maximum output. The maximum input required for 50 mw output should not be over 75 micro-volts. The minimum may run as low as 10 micro-volts. If the set is stable-10 micro-volts will be all right. A normal set will require 25 micro-volts. Use approximately 100 micro-volts input when making IF adjustments. The IF alignment is now complete.

X Set the frequency at the high end of band "A" with condenser C-8 (osc.) Adjust det. trimmer C-2 for maximum gain. Check calibration at the low end of band. 600 kc should fall within \pm 10 kc.

Note: A chart is being supplied which will show calibration and alignment points for each band. This chart will also show tolerances on calibration.

XI Set the band change switch at "B". Set the frequency at the high end of the band. Peak mixer trimmer while rocking the dial for maximum output. Check the calibration at the low end of the band.

XII Repeat Operation XI for band "C" (Band switch at "C".)

XIII Set band switch at "D". Set the frequency at the high end of the band. Peak the mixer trimmer on signal for maximum output while rocking the dial. Check the frequency at the low end of band. On Band "D", adjust loop in det. coil at 14 mc for maximum gain.

Check chart below for calibration and alignment points.

Band	Set	Peak Det. Trimmer at	Check Cal. at Tol.	Check Tracking at
"A"	1.5 mc.	1.5 mc.	.6 mc±10kc.	.6 mc.
"B"	4.0 mc.	3.8 mc.	2.0 mc 20kc.	1.8 mc.
"C"	14.0 mc.	13.5 mc.	5.0 mc±60kc.	5.5 mc.
"D"	28.0 mc.	29.0 mc.	14.0 mc±150kc.	13.5 mc.

The above tolerances apply to the whole band.

SELECTIVITY

Input: 100 micro-volts
Output: level 10 milliwatts

6 db	3.4 kc.
20 db	14.0 kc.
40 db	28.2 kc.
60 db	49.5 kc.

AVC at 2 MC 300 ohm dummy-

Measurement taken here to avoid noise pick-up.

10 micro-volts	=	0 db	=	1 mw.
100	- "	-	+	15
1000	- "	-	+	20
10000	- "	-	+	24
100000	- "	-	+	28.0

Overall distortion at 1 MC

Maximum power 1.8 watts

30% mod. 1000 CPS

Overall fidelity at 2 mc.

100 mw.	2	%
200	2.2	
300	2.6	
500	2.8	
.7	3.5	
.8	4.2	
1.0	6.5	
1.5 watts	10+	

100	-11.0
200	- 5.0
400 cps	0 db
1000	+ 2.0
2000	- 2.0
3000	- 6.5
4000	-12.5
5000	-18.0

GAIN

Dial set at 1000 kc.

Location	Frequency	Input	Output
Mixer Grid	455 kc.	26 uv	50 mw
IF Grid	455 kc.	3000 uv	50 mw
First Audio	400 cps	.5 volts	50 mw
Last Audio	400 cps	1.8 volts	50 mw

Audio response from first audio grid.

Input constant at .4 volts.	100	-12.0
	200	- 5.5
	400	0
	1000	+ 1.8
	2000	+ 1.0
	3000	- .75
	4000	- 3.5
	5000	- 6.5
	10000	-19.0

MODEL SW-54

HUM

As measured on 4 ohms with Ballantine volt meter
 IF grid grounded
 Audio gain off 1.8 micro-watts
 Audio gain full 1.8 micro-watts
 Line cord reversed 1.8 micro-watts

OVERALL GAIN, S/N RATIO, AND IMAGE RATIO

FREQ. MC.	GAIN FOR 50 MW	10 DB SIG/NOISE 300 OHMS	10 DB SIG/NOISE NO. DUMMY	IMAGE DB	50 MW DIRECT	OSC. VOLTS
<u>BAND "A"</u>						
.6	21.5 uv	18 uv	18 uv	43	22	6.6
1.0	11	10	10	42	16.5	9.0
1.5	15	10	10	35	19	9.6
<u>BAND "B"</u>						
1.7	11	11	3.1	30	5.5	4.2
2.5	6	6	2.8	32	2.8	6.2
4.0	7.2	7.7	4.5	20	4.0	7.2
<u>BAND "C"</u>						
5.0	14.0	13	4.5	22	5.5	2.6
8.0	9.4	7.0	2.4	16.0	4.5	3.6
14.0	4.0	4.0	3.8	18.0	3.0	2.2
<u>BAND "D"</u>						
15	28.0	28.0	8.5	8.0	13.5	2.4
20	10	10	8.5	12.0	6.5	2.6
29	4.5	4.5	4.0	6.0	6.0	1.6

SOCKET VOLTAGES

Meter - High impedance D.C. 100 ohms per volt A.C.

All measurements to ground
 Bandswitch at "A"
 No signal
 Dial at 1000 kc.
 Audio gain turned down.

Tube	Pin #1	Pin #2	Pin #3	Pin #4	Pin #5	Pin #6	Pin #7
12BE6	9 DC	.6AC	11AC	22 AC	98 DC	98 DC	.3 DC
12BA6	.3DC	0 AC	22AC	35 AC	35 AC	105 DC	1.1 DC
12AV6	.9DC	0	11AC	0	.45DC	.45DC	72 DC
50C5	7.0DC	0	80AC	35 AC	0	100 DC	120 DC
35Z5	100 DC	115 AC	110AC	0	110 AC	125 DC	80 AC

RESISTANCE MEASUREMENTS TAKEN TO CHASSIS (POWER REMOVED).

Tube	Pin #1	Pin #2	Pin #3	Pin #4	Pin #5	Pin #6	Pin #7	Pin #8
12BE6	22K	.2	11	22	20K	20K	3 meg	
12BA6	2.5 meg.	0	20	30	20K	20K	100	
12VA6	10 meg.	0	11	0	.5 meg	.5 meg	260K	
50C5	150	.5 meg	100	40	.5 meg	.5 meg	20K	
35Z5	22K	120	120	Open Cir.	120	120	85	20K

Primary-output trans. 100 ohms
 Secondary .2 ohms

RESISTANCE OF RF COILS

A Det. Coil Sec.	3.5 ohms	A Det. Coil Prim	29.5 ohms
B Det. Coil Sec.	.83 "	B Det. Coil Prim.	.93 "
C Det. Coil Sec.	.05 "	C Det. Coil Prim	.93 "
A Osc. Coil Total	2.34 ohms		
cold end to trap	.35 ohms		
B Osc. Coil Total	1.01 ohms		
C Osc. Coil Total	.06 ohms		
D Osc. Coil Total	.04 ohms		

Caution: Be sure that no part of the metal frame of the speaker touches the chassis.

Never substitute 10% condensers for the 5% as called for on the parts list. These 5% condensers are used as padders and are C-12, C-13 and 4...470 mmfd ...1000 mmfd and 3000 mmfd.

Length of wires on tuning condenser should not be changed.

SOME TROUBLES AND FAULTY PARTS WHICH COULD BE THE CAUSE

Mushy audio and loud hum.

Defective condenser C-29C or C-29D.

Off signal, audio not mushy on signal.

Be sure the shield on the 12AV6 tube V-3 is properly seated.

Hum modulation in broadcast band.

Try replacing C-33.

Hum modulation in the higher frequency bands-check C-32.

C-39 may be defective.

Oscillation in the IF stage.

C-36 defective

C-35 defective

CW switch does not ground the feed back wire with the CW off.

Plate and grid leads should be down near the chassis.

Pin #2 and center shield on the socket not grounded.

Shorted cathode resistor.

Poor sensitivity at low end of band "B" with almost normal gain at the high end of the band.

C-1 may be open.

Poor sensitivity on all bands and trimmers C-2, 3 and 4 do not peak properly.

C-6 open.

High frequency oscillator does not work at some spot in one of the bands.

Poor contact on shorting rotor on band change switch.

PARTS LIST

Symbol No.	Description	Nat. Co. Type			
CAPACITORS					
C-1	Paper .01 mfd 400 vdcw	D827-5	C-7	Ceramic 10 mmf 500 vdcw	D827D-426
C-2	Variable mica 2.2-40 mmf 500 vdcw	D832-5	C-8	Variable mica 2.2-40 mmf	D832-5
C-3	Variable mica 2.2-40 mmf	D832-5	C-9	Variable mica 2.2-40 mmf	D832-5
C-4	Variable mica 2.2-40 mmf	D832-5	C-10	Variable mica 2.2-40 mmf	D832-5
C-5	Variable mica 2.2-40 mmf	D832-5	C-11	Variable mica 2.2-40 mmf	D832-5
C-6	Paper .02 mfd 200 vdcw	D827-51	C-12	Mica 470 mmf 500 vdcw	J665-55
			C-13	Mica 1000 mmf 300 vdcw	J665-70
			C-14	Mica 3000 mmf 500 vdcw	J666-30
			C-15	Ceramic 21 mmf 500 vdcw	D825D-410
			C-16	2 section variable	K577-2
			C-16A	12 to 441.7 mmf	Part of C-16

MODEL SW-54

C-16B	12 to 441.7 mmf	Part of C-16
C-17	Ceramic 3 mmf	J695-4
C-18	Ceramic 100 mmf	J695-6
C-19	87 mmf	Part of T-1
C-20	87 mmf	Part of T-1
C-21	Paper .01 mfd 400 vdcw	D827-5
C-22	110 mmf	Part of T-2
C-23	110 mmf	Part of T-2
C-24	110 mmf	Part of T-2
C-25	110 mmf	Part of T-2
C-26	Paper .005 mmf 200 vdcw	D827-50
C-27	Paper .005 mmf 200 vdcw	D827-50
C-28	Mica 4700 mmf 500 vdcw	J665-56
C-29	4 section dry electrolytic	Q252-1
C-29A	5 mfd	Part of C-29
C-29B	40 mfd	Part of C-29
C-29C	40 mfd	Part of C-29
C-29D	60 mfd	Part of C-29
C-30	Paper .02 mfd 600 vdcw	D827-44
C-31	Paper .02 mfd 200 vdcw	D827-51
C-32	Mica 470 mmf 500 vdcw	J665-56
C-33	Paper .1 mfd 400 vdcw	D827-12
C-34	Paper .02 mfd 600 vdcw	D827-44
C-35	Paper .02 mfd 200 vdcw	D827-51
C-36	Paper .25 mfd 200 vdcw	D827-15
C-37	Variable ceramic 2 section	Part of T-1*
C-37A	35-150 mmf	Part of C-37
C-37B	35-150 mmf	Part of C-37
C-38	Variable ceramic 2 section	Part of T-2*
C-38A	35-150 mmf	Part of C-38
C-38B	35-150 mmf	Part of C-38

RESISTORS

R-1	Fixed 470,000 ohms 1/2 watt	J569-57
R-2	Fixed 47 ohms 1/2 watt	J569-9
R-3	Fixed 47 ohms 1/2 watt	J569-9
R-4	Fixed 100 ohms 1/2 watt	J569-13
R-5	Fixed 47,000 ohms 1/2 watt	J569-45
R-6	Variable 500,000 ohms w/switch	K347-6
R-7	Fixed 2,200,000 ohms 1/2 watt	J569-65
R-8	Fixed 10,000,000 ohms 1/2 watt	J569-73
R-9	Fixed 220,000 ohms 1/2 watt	J569-53
R-10	Fixed 470,000 ohms 1/2 watt	J569-57
R-11	Fixed 150 ohms 1/2 watt	J569-15
R-12	Fixed 15,000 ohms 1 watt	J571-39
R-13	Fixed 220 ohms 1/2 watt	J569-5
R-14	Fixed 22 ohms 1/2 watt	J569-22
R-15	Fixed 1000 ohms 1 watt	J571-25
R-16	Fixed 330 ohms 1/2 watt	J569-19
R-17	Fixed 22,000 ohms 1/2 watt	J569-41

*Alternate IF Trans.

MISCELLANEOUS

E-1	Antenna terminal board 3 terminal	E261-3
-----	-----------------------------------	--------

E-2	Terminal board, speaker output, 2 terminal	E264-1
I-1	Lamp, #47 bayonet type 6-8 v 15 amps	F136-11
L-1	Inductor, detector "A" coil air core	SA:7971
L-2	Inductor, detector "B", "C" and "D" coils air core	SA:7973
L-2A		Part of L-2
L-2B		Part of L-2
L-2C		Part of L-2
L-3	Inductor, oscillator "A", "B", "C" and "D" coils air core	SA:7981
L-3A		Part of L-3
L-3B		Part of L-3
L-3C		Part of L-3
L-3D		Part of L-3
L-4	Inductor, variable, iron core tuning	Part of T-1
L-5	Inductor, variable, iron core tuning	Part of T-1
L-6	Inductor, variable iron core	Part of T-2
L-7	Inductor, variable iron core	Part of T-2
LS-1	Loudspeaker, 4" PM	Q374-1
S-1	Switch, band selector, 2 pole 4 pos	SA:7972
S-1A		Part of S-1
S-1B		Part of S-1
S-2	Switch, CW-AM, 2 pole 3 pos	SA:7977
S-3	Switch, standby, 2 pole 3 pos	SA:7978
S-4	Switch, phone, 2 pole 3 pos	SA:7976
S-5	Switch, on off, spst	Part of R-6
T-1	Transformer, IF, 455 Kc., shielded	Q242-1
T-1*	Transformer, IF, 455 Kc., shielded	Q243-1
T-2	Transformer, IF, 455 Kc., shielded	Q242-2
T-2*	Transformer, IF, 455 Kc., shielded	Q243-2
T-3	Transformer: speaker matching, primary 2500 ohms secondary 3.2 ohms, iron core	K588-2
V-1	Tube, converter, 12BE6	
V-2	Tube, pentode, 12BA6	
V-3	Tube, duo diode triode, 12AV6	
V-4	Tube, beam power amplifier, 50C5	
V-5	Tube, full wave rectifier, 35Z5	
Z-1	Filter, one 47,000 ohm resistor and two 100 mmf. capacitors	Q262-1
	*Alternate IF Trans.	

MECHANICAL PARTS

Bracket, main support	Q228-1
Bracket, to mount coil (2)	Q249-1
Bracket, pulley support	SA: 7969
Bumper, rubber: chassis insulator	Q258-1
Cabinet	SA: 7979
Channel, rubber	Q255-1
Chassis, metal wraparound less all components	Q227-1
Clip for miniature tube	K925-1
Collar for dial shaft	D637-4

Cord, AC Line

Cord, dial	Q241-1
Cover, bottom of cabinet	SA: 7975
Cover, rear of cabinet	Q224-1
Foot (4)	Q223-1
Knob, large	Q237-1
Knob, small (2)	SA: 5692-2
Pad, rubber	SA: 7984
Plate, for switch	Q254-1
Pointer, dial scale	Q235-1
Rail, for pointer	Q240-1
Ring, retaining (dial shaft)	Q234-1
Scale, slide rule type	P491-3
	Q233-1

Shaft, dial

Shield, for miniature tube	K924-1
Socket, for dial light	J721-2
Socket, miniature 7 pin (4)	K926-2
Socket, octal type	Q236-1
Strap, for speaker mounting	Q235-1
Washer, stop, for dial shaft	P149-2
Washer, stop, for dial shaft (6)	P149-1
Window for the slide rule scale	Q225-1

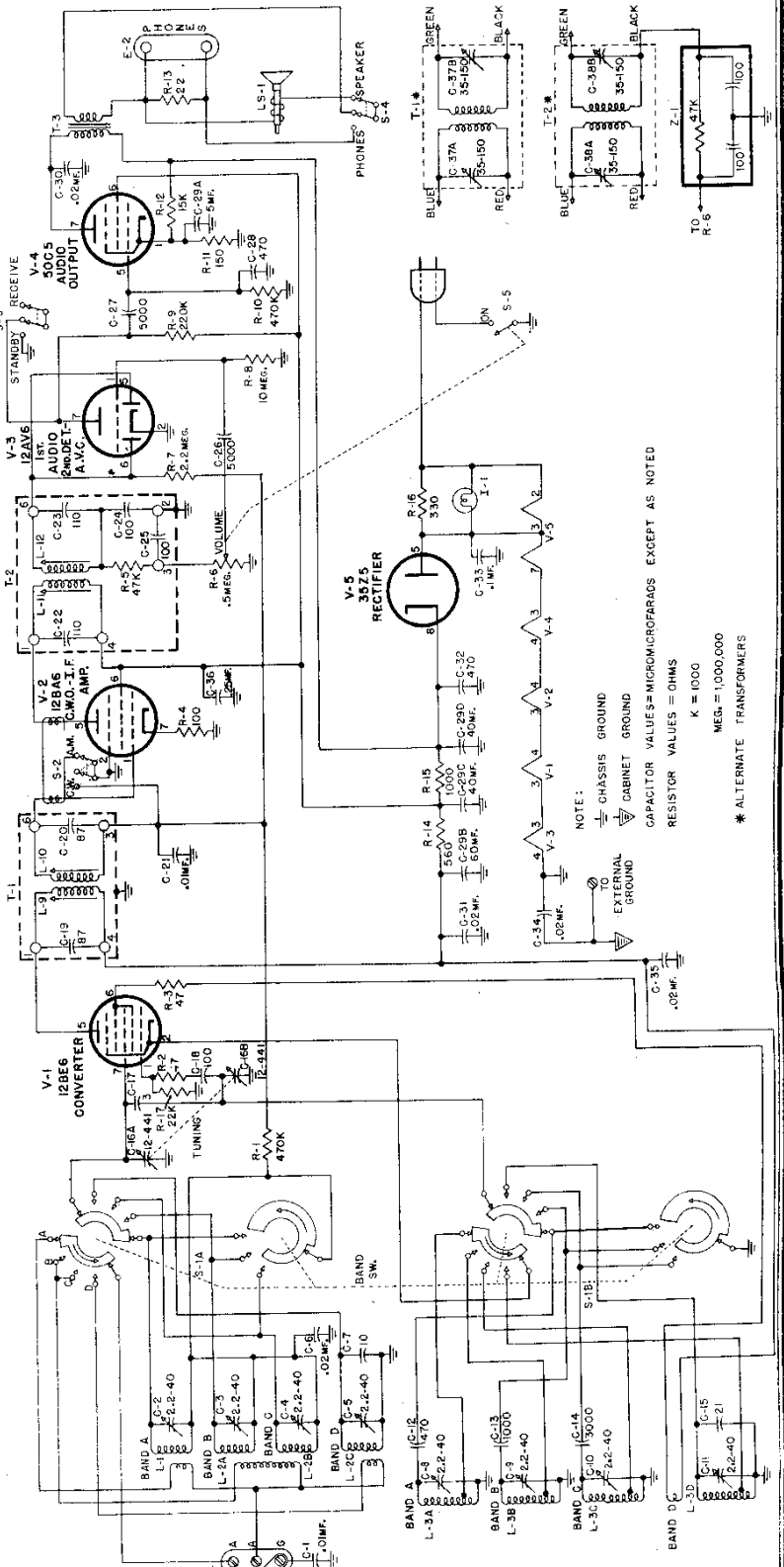

NOTE:
 TO CHASSIS GROUND
 TO CABINET GROUND
 TO EXTERNAL GROUND

CAPACITOR VALUES = MICROMICROFARADS EXCEPT AS NOTED
 RESISTOR VALUES = OHMS

K = 1000
 MEG. = 1,000,000

* ALTERNATE TRANSFORMERS

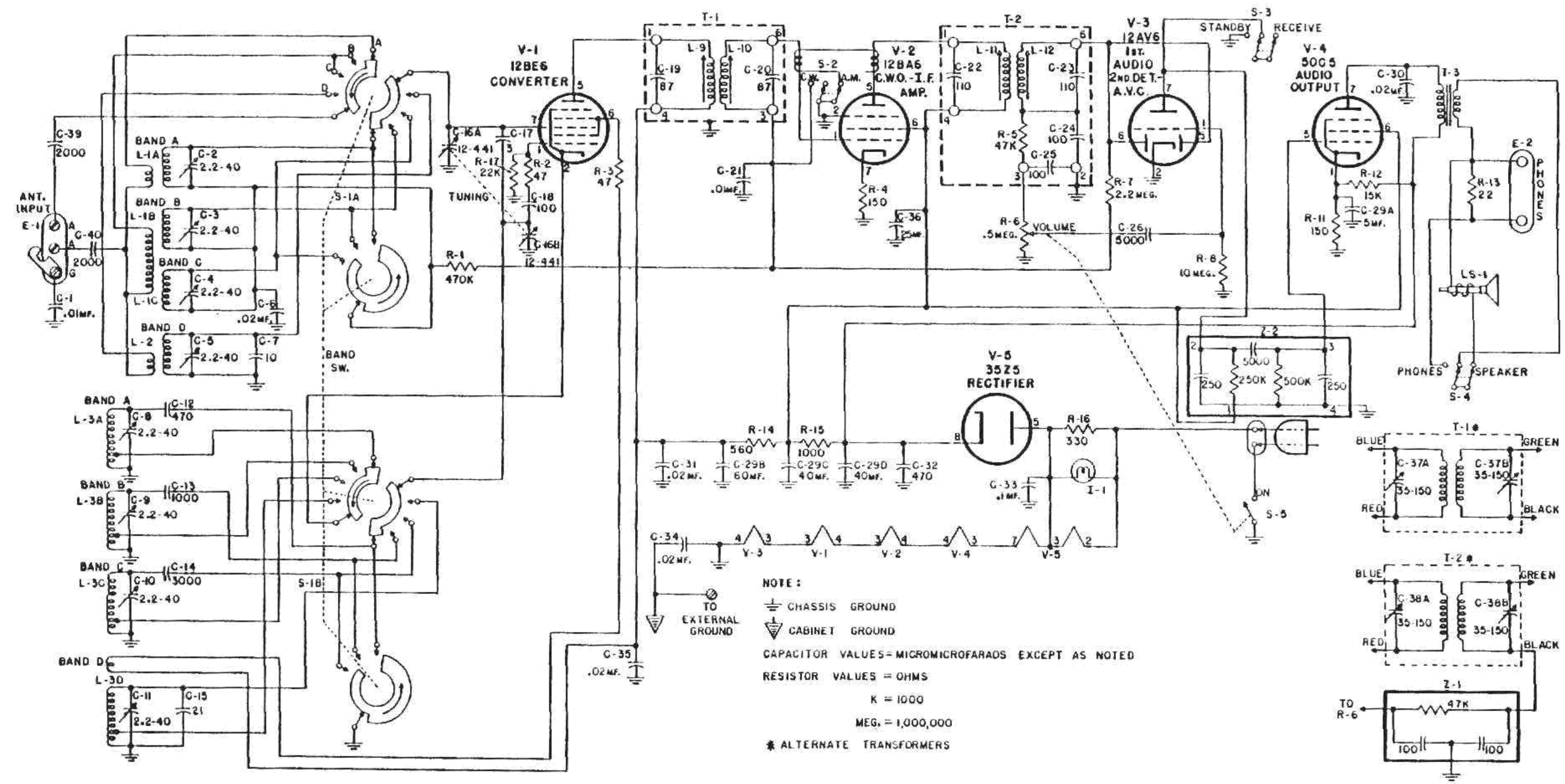

NOTE:

- ⊥ CHASSIS GROUND
- ⊥ CABINET GROUND
- CAPACITOR VALUES = MICROMICROFARADS EXCEPT AS NOTED
- RESISTOR VALUES = OHMS
- K = 1000
- MEG. = 1,000,000
- * ALTERNATE TRANSFORMERS

