

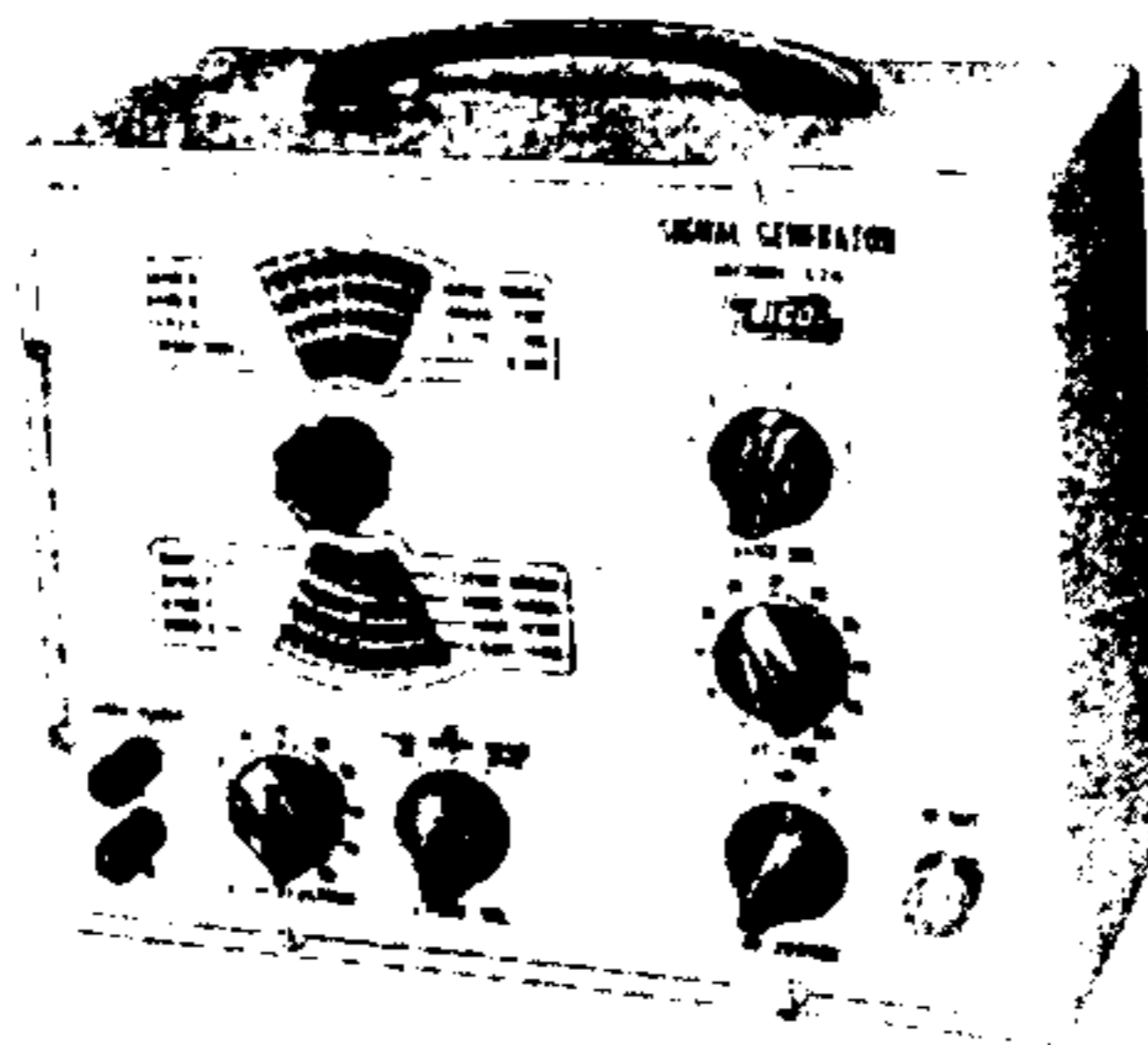

# INSTRUCTION MANUAL

---

**Model 324**



# SIGNAL GENERATOR

MODEL 324



BAND A — 150 KC - 400 KC  
BAND B — 400 KC - 1.2 MC  
BAND C — 1.2 MC - 3.5 MC  
LINEAR SCALE — 0 - 100

BAND F2 — 110 MC - 435 MC  
BAND F1 — 37 MC - 145 MC  
BAND E — 11 MC - 37 MC  
BAND D — 3.5 MC - 11 MC

BAND SEL.

RF FINE

RF COARSE



RF OUT

AUDIO IN/OUT



AF MOD/OUTPUT

POWER OFF  
RF EXT. MOD.  
INT. MOD. AF OUT

SIGNAL SEL.

## GENERAL DESCRIPTION

The EICO Model 324 RF Signal Generator is intended for general radio and television servicing and for other applications requiring a modulated or unmodulated r-f signal of sine waveform from 175kc to 420mc.

The r-f output from the Model 324 may be modulated internally by a 400 cps audio oscillator or may be modulated externally by an audio signal fed into a connector on the front panel. The internal 400 cps modulating signal is also available separately at a front-panel connector. Selection of external modulation rearranges the audio oscillator stage as an amplifier operating on the external modulation signal. As a result, up to 30% modulation is possible when the output of the external a-f source is as low as 3.0 volt. Percentage modulation by either an internal or external a-f source, as well as a-f output voltage, is adjustable by a single panel control.

Six tuning bands are employed to cover the fundamental frequency range from 150kc to 145mc. Calibration of the third harmonic of the highest fundamental band (F1) 37 mc to 145 mc is also given on the tuning dial to provide a seventh tuning band (F2) from 111 mc to 435 mc. The particular band desired is selected by the band selector switch which acts, therefore, as a coarse output frequency selector; the 6 to 1 vernier tuning dial control is for fine tuning and permits exact setting of the output frequency.

Construction of the dial and tuning assembly is unusually fine. A heavy gauge, deep-etched, aluminum tuning dial is fastened to the shaft of the tuning capacitor behind the panel and rotates with the tuning knob. The dial is viewed through twin plexiglass windows, four complete scales appearing in one window and four in the other, so that, despite the large number of scales, they are well-spaced and not easily confused. The plexiglass not only affords protection for the tuning dial, but, due to its unique light-conducting property, permits the use of an illuminated hairline, which is engraved in the plexiglass and edge-lit by a panel lamp to permit maximum ease of reading. The illuminated hairline also serve as a pilot. Other important construction points include the use of turret mounted, slug-tuned coils for maximum accuracy, copper-plated chassis for minimized interference, line filters, shielded r-f output cable and jack-top binding posts for audio in/out.

The Model 324 incorporates both coarse and fine r-f attenuators for smooth, efficient control of the r-f output signal. The coarse attenuator provides two steps of coarse attenuation of approximately 20 db each.

The Model 324 employs a Colpitts-type r-f oscillator and a Colpitts-type audio oscillator of proven design for efficient and trouble-free operation. The r-f

oscillator is plate modulated by a cathode follower for improved modulation. Maintenance is simplified by an uncrowded chassis and easy access to all internal alignment adjustments for the six fundamental r-f bands.

The characteristics of the Model 324 render it extremely flexible. It may be used in the radio and television service shop or in the field for such applications as alignment and signal tracing of am and fm radio receivers, alignment of both high and low frequency i-f amplifiers in television receivers, and signal tracing and troubleshooting almost all sections of tv receivers. The Model 324 is equally suitable to bench or portable applications, being provided with an uncluttered, professional satin aluminum panel that will add to the appearance of any test bench and a rugged steel case that will withstand "car trunk" abuse.

## **SPECIFICATIONS**

### **RF CHARACTERISTICS:**

RF Output Frequency Range . . . . . 150kc to 145mc on fundamentals in 6 bands  
111mc to 435mc on calibrated harmonics.

Accuracy of Tuning Dial Calibration.  $\pm 1.5\%$

RF Coarse Attenuation . . . . . in two steps, each approximately 20 db

RF Fine Attenuation . . . . . continuous 0 to max.

### **AF CHARACTERISTICS:**

Internal AF Modulating Frequency . . . approx. 400 cps

AF Output Voltage . . . . . adjustable 0 to 10 volts across 100K $\Omega$   
load; adjustable 0 to 5 volts across 10K  
ohm load.

AF In Impedance . . . . . approx. 70K $\Omega$

AF Out Impedance . . . . . approx. 10K $\Omega$

### **MODULATION CHARACTERISTICS:**

Percentage Modulation by Internal 400 cps signal . . . . . adjustable 0 to 50%

**External Modulation Frequency Range . . . . . 20 - 15,000 cps**

**External AF Voltage Required for 30% Modulation at 1 mc RF Setting (1000 cps signal) . . . . . approx. 3.0 volts.**

**TUBE COMPLEMENT: 1-12AU7, 1-12AV7, 1 selenium rectifier.**

**POWER REQUIREMENTS: 105-125 volts AC, 50/60 cps; drain 15 watts.**

**DIMENSIONS: 8" high, 10" wide, 4 3/4" deep.**

**WEIGHT: 10 lbs.**

## **FUNCTIONS OF CONTROLS AND TERMINALS**

**SIGNAL SEL.** - Turns power off in "OFF" position. In "INT. MOD./AF OUT" position, modulated r-f output is available at the RF OUT connector and 400 cycle audio signal is available at the AUDIO IN/OUT connectors. In "RF/EXT. MOD" position, pure or externally modulated r-f output is available at the RF OUT connector depending on whether or not any external modulating signal is fed to the AUDIO IN/OUT connectors.

**BAND SEL.** - Used to select desired tuning band. Frequencies in lower three bands (from 150kc to 3.5mc) as well as the linear reference scale are read in the upper window. Frequencies in higher four bands (3.5mc to 435mc) are read in the lower window. Note that position F is used when tuning frequencies in either band F1 or F2.

**TUNING** (knob between windows): - Permits adjustment of RF output frequency to exact value. The RF output frequency is the setting directly under the illuminated hairline on the scale for the band selected with the BAND SEL.

**RF OUT** - The output cable supplied with the Model 324 should be connected to the RF OUT connector. The amount of output voltage is controlled by the RF COARSE and RF FINE attenuators.

**RF COARSE** - Permits adjustment of the RF output in coarse steps of approximately 20db each. This is a primary rather than a secondary adjustment.

**RF FINE** - Continuous control permits exact adjustment of the RF output voltage. This is a secondary rather than a primary adjustment.

**AUDIO IN/OUT** - Has a double function. When the SIGNAL SEL. switch is set to "INT. MOD./AF OUT", a 400 cps audio signal from the internal audio

oscillator is fed to this connector. The audio output voltage is adjustable from zero to a maximum depending upon the load by the AF/MOD. OUTPUT control. When the switch is turned to "RF/EXT. MOD." an external modulating signal up to 15kc may be injected at AF IN/OUT to modulate the r-f output taken from the RF OUT connector.

**NOTE:** When using external modulation, the AF MOD./OUTPUT control should be turned clockwise in order to prevent short-circuiting the modulating signal to ground. In use, this control may be used as an attenuator to adjust the amount of injected modulating signal. As the Model 324 provides a stage of amplification for the external modulating signal, a signal of only 3.0 volts approximately is required to modulate the r-f oscillator to 30% at 1000 cps (at 1 mc RF setting).

**AF MOD/OUTPUT** - Has three functions. 1) Adjusts the percentage of internal modulation when the SIGNAL SEL. is set at "INT. MOD./AF OUT. 2) Adjusts the amount of audio signal available at the AUDIO IN/OUT connectors when the SIGNAL SEL. is set at "INT. MOD./AF OUT". 3) Adjusts the percentage of external modulation when the SIGNAL SEL. is set at "RF/EXT. MOD." and an external modulating signal is injected at the AUDIO IN/OUT connectors.

## **APPLICATIONS**

**NOTE:** Agc troubles may cause r-f or i-f amplifiers to appear weak, dead, or intermittent. Where doubtful, eliminate agc for the test and use fixed bias as shown in Fig. 1.

**WARNING:** Do not connect the 324 to test circuit points having operating voltages exceeding the maximums listed below:

RF OUT Connector - 500 dc volts max.

AF IN/OUT Connector - 400 dc volts max.

## **TV SERVICING:**

General: If a tv set being serviced has picture or raster trouble, first check the ion trap magnet, brightness control, focusing magnet, and drive control in order to see whether a normal raster with normal brightness is obtainable. The picture tube, the high voltage section, and the vertical and horizontal deflection circuits are o.k. if a normal raster is obtained. If you have a poor raster or no raster, check these sections and correct the trouble. When you have a normal raster, apply picture signal with the contrast control set for max. contrast. If you get a weak picture or no picture, it indicates that there is probably trouble in the r-f, i-f, or video sections.

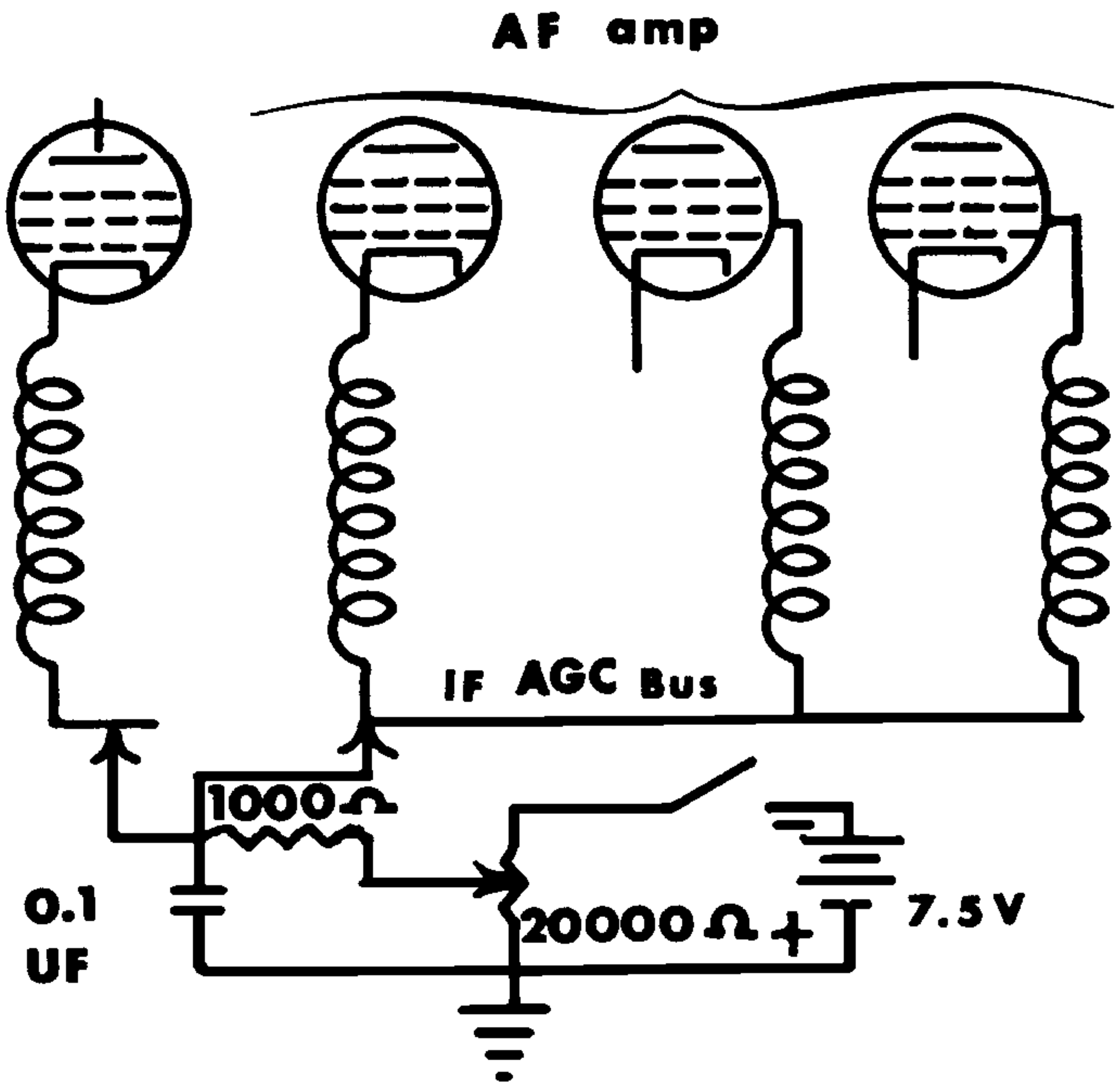

**FIG. 1. ELIMINATING AGC AND USING FIXED BIAS**

Dead Stage Location in video amplifiers: Check the video section by applying a few volts of audio to the input of the video section (point 1 Fig. 2). As a result, about 6 horizontal bars (the frequency of the a-f output, 400 cps, is about 6 times the normal vertical oscillator operating rate, 60 cps) should appear on the raster as shown in Fig. 3. Adjust the vertical hold control to keep the bars stationary. If the bars do not appear, check out the video section point-by-point starting at the picture tube input and working back toward the 2nd detector. The gain provided by each stage should result in darkening of the bars when the 324 audio lead is moved from the plate to the grid of the same stage if the stage is operating. Distinct lightening of the bars when the 324 audio lead is moved from the grid of one stage to the plate of the preceding stage indicates a faulty coupling capacitor. Reduce the audio voltage applied to avoid overloading as required.

Dead stage location in picture i-f amplifiers: If the video amplifier is o.k., check the picture i-f section as follows. Tune the 324 to the center of the picture i-f pass band. Apply a modulated r-f signal at the input of the picture

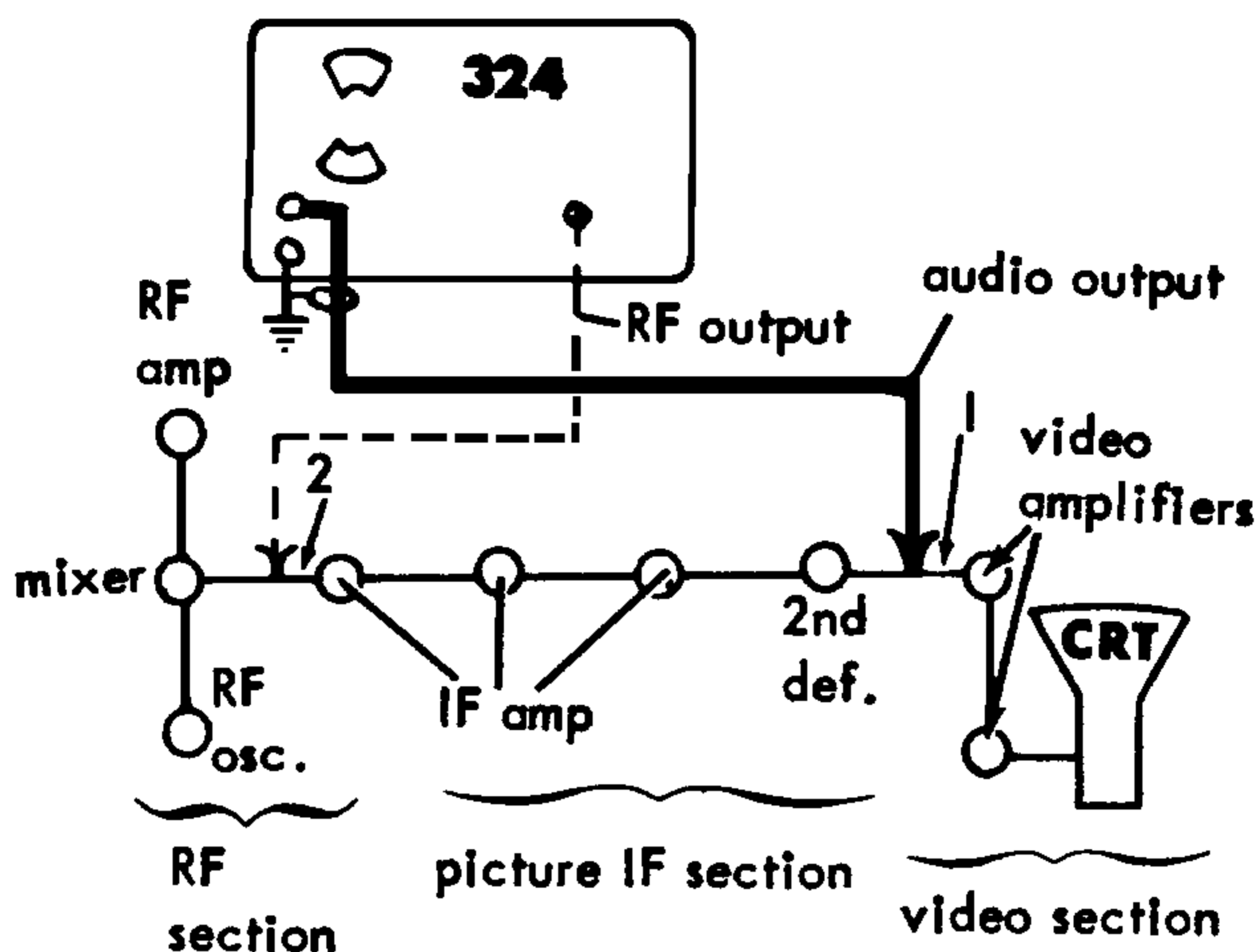

FIG. 2. BLOCK DIAGRAM OF TV RECEIVER SHOWN WITH OUTPUT OF 324 APPLIED TO KEY CHECK POINTS



FIG. 3. HORIZONTAL BARS PRODUCED BY 400 CPS MODULATION ON SCREEN OF TV RECEIVER

i-f amplifier (point 2, Fig. 2). If horizontal bars do not appear on the raster, check the agc voltage according to the manufacturer's service notes. A shorted i-f tube or agc bus may result in clipping. If the agc circuit seems o.k., check out the picture i-f section point-by-point starting at the grid circuit of the last picture i-f amplifier and working back toward the first i-f amplifier. The gain provided by each stage should result in darkening of the bars when the 324 r-f lead is moved from the grid of the following stage to the grid of the stage under test if the stage is operating. Reduce the 324 output voltage with the output cable connected to the plate of a stage to obtain light bars so that the stage gain will be observable as darkening of the bars when the output cable is moved to the grid of the stage.

If the picture i-f stages are functioning properly, check the mixer stage by applying r-f signal to the grid. If the receiver is designed so that the r-f tuned circuits act as a partial i-f short across the converter grid, temporarily eliminate the short during this procedure by a) removing a mixer coil strip in tuner of the turret type and turning the turret to the blank position, or b) using a spare mixer tube, carefully bending out the grid pin for connection to the signal



generator. In step b and sometimes in a, you will need to use a 10K $\Omega$  or larger resistor to ground to supply a dc-return path for the grid current.

Locating a dead r-f amplifier or r-f oscillator stage: If the mixer stage, picture i-f section and video sections are ok, determine whether the r-f oscillator is operating by measuring the negative grid bias developed in the oscillator circuit. It is important to use a vtvm such as the EICO 221, 214, 232, or 249 for this measurement. The correct value of the bias voltage should be obtained from the service notes for the particular set. As the range of value for this voltage is usually from -2 to -6 volts, a measurement of a few tenths of a volt or less indicates the r-f oscillator is not functioning and the supply voltages, tube, and other parts of the circuit should be checked. If the r-f oscillator is functioning properly, tune the receiver to any desired vhf channel and the 324 to the picture carrier frequency of that channel. Apply the modulated r-f signal to the mixer tube grid and adjust the r-f output so the bars are clearly visible on the picture tube screen.

Note: Tuners employing triode mixers and some employing pentode mixers may require that a capacitor of about 5 uuf or less be connected in series with the r-f lead to minimize circuit loading and avoid detuning of the high impedance circuits.

Move the output cable to the plate of the r-f amplifier. The bars may turn lighter in shade. If the bars become very faint or disappear entirely, look for trouble in the r-f tuned circuits between the r-f amplifier plate and the converter grid. Without moving the cable, reduce the 324 r-f output until the bars are light grey and then shift it to the grid of the r-f amplifier. Darker bars should result, indicating that the r-f amplifier is functioning. Finally, shift the cable to the antenna input terminals of the receiver, which should result in bars of about the same intensity as before. Faint bars or disappearance of the bars indicates trouble in the circuits ahead of the r-f amplifier.

Locating a dead stage in the sound i-f amplifier: Normal picture but no sound indicates that the trouble is probably in the sound circuits following the sound i-f take-off circuit. If the audio section of the receiver tests o.k. (use method described in later section), check the f-m sound detector. In either the ratio detector or discriminator type detectors, set your vtvm up to use the zero-center scale and connect it across the output load resistor of the detector. Connect the r-f output cable of the 324 to the grid of the last sound i-f stage and tune the generator to the center frequency of the sound i-f amplifier. Tune the 324 back and forth through the sound i-f setting. If the detector is aligned and operating properly, the vtvm meter pointer will swing above and below center scale as the 324 is tuned. If the last stage or detector is defective, however, performance may be impaired.

Next, set up your vtvm to measure dc volts and connect it to the grid of the

last sound i-f stage. Normally, grid current flowing through the grid resistor of this stage when a sound i-f signal is applied will produce a negative dc voltage varying from -1.0 volt on weak signals to -30 volts or more on strong signals. At no signal, contact potential in the tube will produce a negative voltage of a few tenths of a volt. Tune the 324 to the center frequency of the sound i-f amplifier and apply the full r-f output, unmodulated, to the input of the sound i-f amplifier. If no reading is obtained, check out the sound i-f amplifier point-by-point by shifting the 324 i-f output cable first to the plate of the next-to-last sound i-f stage, then to the grid, and so on to the input.

Localizing intermittent picture troubles where raster is not affected: Tune the tv receiver to an unused channel at the high end of the band. Tune the 324 to the center of the picture i-f pass band and apply it with modulation to the input of the picture i-f amplifier. Adjust the 324 output and receiver contrast control until the horizontal bars are clearly visible. Set your vtvm to a low d-c voltage range and connect it across the second detector load resistor where it should read several volts of rectified signal. If, when the intermittent occurs, the bars disappear but the vtvm reading remains unaltered, you know the trouble is in the video section or the picture tube. If the intermittent does not occur, the trouble is probably in the r-f section. Intermittents due to voltage breakdown, such as in capacitors or other components may be speeded up by operation at higher than normal line voltage. Intermittent r-f oscillator action due to low line voltage (possibly due to weak or defective oscillator or power rectifier, or dirty tuner contacts) may be induced by operating the receiver at lower than normal line voltage. Intermittent contacts may be found by inspection or tapping and prodding suspected components, whereas intermittents due to contraction and expansion as a result of temperature changes may be induced by heating the components in the suspected section with an infra-red lamp or an ordinary electric lamp.

Localizing intermittent sound trouble: Intermittent sound but normal picture indicates that the trouble is probably in the sound i-f or audio section of the receiver. (Similar symptoms may result from r-f oscillator frequency shift in receivers having a separate a sound channel.) To determine whether the trouble is in the sound i-f or audio section, set your vtvm at the 50 volt d-c range or thereabouts and connect it to the output of the sound i-f detector. Set the 324 for modulated r-f output and connect the output cable to the input of the sound i-f amplifier. Tune the 324 to a frequency a little above the frequency resulting in maximum positive or negative swing on the vtvm scale. Turn up the receiver volume control and then reduce the 324 output so that the i-f signal is slightly below the limiting level. Reset the volume control for desired sound level. If, when the sound disappears, the meter reading drops to a low value, then the trouble is in the sound i-f amplifier. If the meter reading remains unaffected, look for trouble in the audio section. The occurrence of the intermittent may be speeded up here also by the methods described previously.

**Locating a weak or faulty stage by gain measurements:** The procedures already described are applicable only to finding a dead, extremely weak, or intermittent stage. Where the fault is a definitely weak but not dead stage, it can be located by stage gain measurements. To make stage gain measurements on i-f and r-f amplifiers in receivers employing agc, disable agc and use fixed bias as shown in Fig. 1. A low bias voltage such as -1.5 volts will usually be satisfactory and provide nearly maximum gain, whereas -3 volts may be necessary to decrease the gain of high gain amplifiers or in noisy locations. A bias of -4.5 or -7.5 volts may be required if oscillation occurs at lower bias voltage.

To check stage gain in the video or audio amplifier sections, connect the audio output terminals of the 324 to the grid of the output tube and adjust the audio voltage at that point (as measured on your vtvm) to 1.0 volt. Now shift the vtvm lead to the plate of the tube and measure the signal voltage there. As the voltage gain of the stage is equal to the signal voltage at the plate divided by the signal voltage at the grid, the numerical value of the signal voltage measured at the plate is the gain of the stage. Repeat this procedure for the first stage. In ac/dc receivers and some small ac receivers a hum voltage up to 10 or 15 volts may be present at the plate of the output tube. Measure this voltage with no signal applied and subtract it from the value obtained with signal before calculating the stage gain.

To check stage gain in the picture i-f amplifier, replace agc by fixed bias. Then connect the r-f output cable of the 324 to the grid of the last picture i-f tube and adjust the r-f output without modulation to produce 0.5 volt across the second detector load resistor, as measured with your vtvm. Next, shift the output cable of the 324 to the grid of the next-to-last i-f tube and read the vtvm again. Divide this reading by the first reading (0.5 volt) to obtain the gain of the next-to-last stage. Now reduce the 324 r-f output to again produce 0.5 volt across the load resistor and shift the cable to the grid of the second from last stage. Read the new voltage across the load resistor. This reading divided by 0.5 volt is the gain of the second from last stage. Any other stages may be checked in the same manner.

## **RADIO SERVICING:**

**Locating a dead section in an a-m receiver:** (Unless stated otherwise, the indication of normal functioning in all cases is a loud 400 cps tone.) Check the audio section by applying 0.1 volt audio signal from the 324 to the input of the audio amplifier (point 1 Fig. 4) with the volume control of the receiver set for full volume. Check the i-f section by tuning the 324 to the i-f frequency (usually 455 kc) and applying a very low modulated i-f signal to the input of the i-f amplifier (point 2, Fig. 4). If both audio and i-f sections are functioning, it may be assumed that the trouble is in the r-f section.

Locating a dead stage in the audio amplifier section of a radio or tv receiver:  
Check the speaker and output transformer by applying the full audio output to the primary of the output transformer. Check the audio-output stage by applying almost the full audio output to the grid of the output stage.

Turn up the receiver volume control to maximum and shift the 324 audio lead from the grid of the output stage to the plate of the 1st audio stage. The sound level should remain unchanged if the intervening coupling capacitor is o.k. Now reduce the audio output of the 324 until the 400 cps tone is weak and shift the audio lead to the grid of the 1st audio stage. Proper functioning of this stage is indicated by greatly increased volume. Check the volume control by applying 0.1 volt across it and turning it through its complete range. Noise may be caused by a defective control or d-c leakage in the associated blocking capacitors. To check the input coupling capacitor, shift the audio lead ahead of it. There should be practically no change in volume.

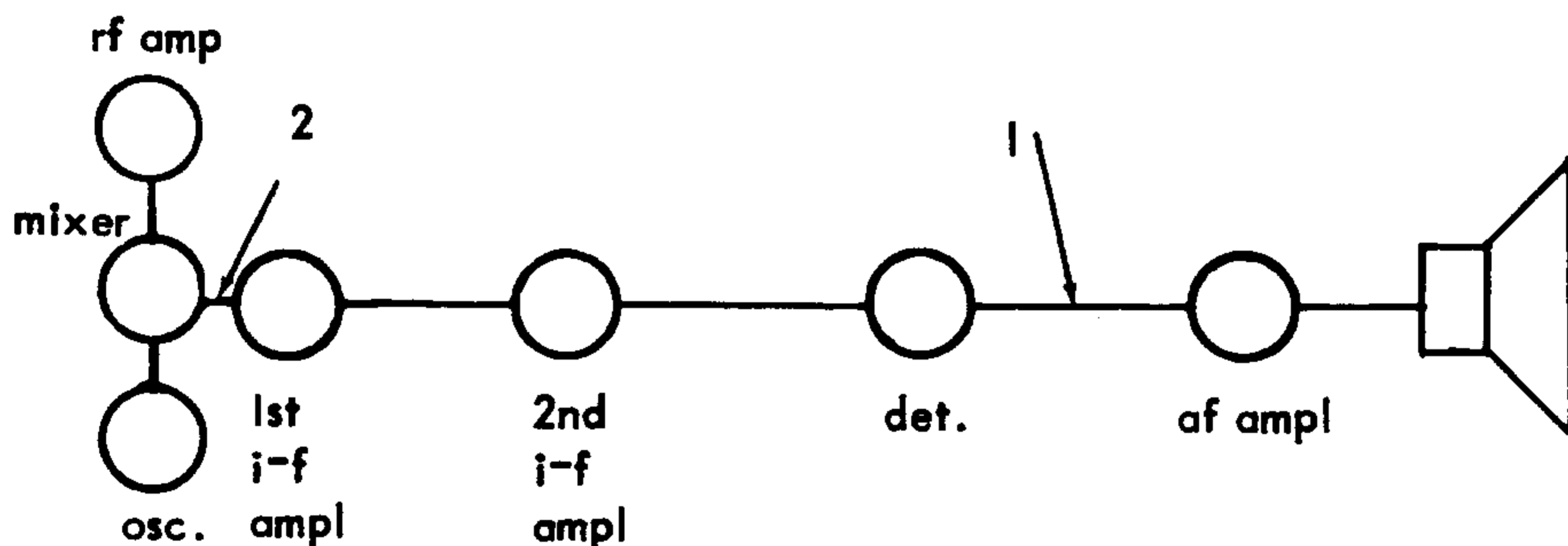

FIG. 4. BLOCK DIAGRAM OF A-M RECEIVER

Locating a dead stage in the i-f amplifier section of an a-m broadcast receiver:  
If the audio section is functioning, the i-f stages may be checked in the same way the picture i-f stages of a tv receiver were checked, except that the indication here is the 400 cycle tone. Start by setting up the 324 for modulated r-f output, tune it to the receiver i-f frequency, and apply a very low level signal to the grid of the second i-f amplifier. Retune the generator for peak sound output. With the receiver volume control turned all the way up, a loud 400 cycle tone should result, indicating proper functioning of the second i-f amplifier and second detector circuits. Check the first i-f stage in the same manner. Check the converter stage by shifting the 324 output cable to the grid of the converter tube. Where the r-f tuned circuits form a partial i-f short across the converter grid circuit, connect a 10K $\Omega$  resistor between the converter grid and the r-f tuned circuit when checking the converter stage and remove after completing the test.

**Checking i-f transformers and i-f coupling capacitors:** To check an i-f coupling transformer, apply a modulated i-f signal to the grid circuit side of the transformer and then to the plate circuit side. While the 400 cycle tone may be somewhat reduced on the plate circuit side, a drastic reduction in sound level or disappearance of the tone indicates a faulty coupling transformer. Coupling capacitors may be checked in the same way.

**Locating a dead r-f stage or r-f oscillator in an a-m broadcast receiver:** Operation of the r-f oscillator is checked by the same method used to check the r-f oscillator in a tv receiver as described previously, that is measuring the negative grid bias developed. In a-m receivers, the value of this voltage ranges from -5 to -15 volts.

If the r-f oscillator is functioning, check the r-f amplifier as follows. Apply a low level, modulated 600 kc signal from the 324 with a 5 uuf (approx.) capacitor in series with the output cable to the signal grid of the mixer tube. Tune the receiver for peak intensity of the 400 cycle tone and adjust the volume to a comfortable level. Now shift the 324 cable to the plate of the r-f amplifier. A considerable reduction or disappearance of the 400 cycle tone indicates trouble in the coupling circuit between the r-f amplifier and the converter stage. Check the r-f amplifier by shifting the 324 output cable to the grid of the r-f stage and retune the receiver slightly, if necessary, for the greatest sound intensity. While the output may increase slightly when shifting the cable from plate to grid, a considerable reduction or weakening of the sound indicates trouble in the r-f amplifier circuit. Finally, shift the output cable to the antenna coil input. A slight increase or decrease in output is normal, but considerable weakening or disappearance of the sound indicates a defect in the antenna coil.

**Checking i-f amplifier gain in an a-m broadcast receiver:** Tune the 324 to the i-f frequency and feed the unmodulated output to the grid of the first i-f amplifier. Adjust the r-f output to develop 10 volts across the second detector load resistor as measured with a vtvm. Now using your vtvm with an RF probe (such as an EICO PRF-11 or PRF-25), measure the generator output voltage at the i-f amplifier grid. The gain is equal to 10 volts divided by the measured generator output voltage.

**Correcting contact potential effect:** If the second detector of the receiver is a vacuum-tube diode, in making gain checks you may need to correct for the dc voltage across the second detector load resistor due to contact potential, particularly when the signal at the second detector is weak. You may do this by first eliminating any input signal to the second detector by temporarily removing an i-f tube and then measuring the dc voltage across the second detector load resistor with your vtvm. This value which may range from 0.1 volt to 0.5 volt must be subtracted from all subsequent measurements of voltage across the second detector load resistor for the purpose of gain calculations.

**Peak Alignment of a-m and f-m broadcast receivers:** I-f alignment is basically the same for both a-m and f-m receivers. Manufacturer's instructions in any case should be followed as closely as possible. In general, the following procedure may be used.

Set up your vtvm to read d-c voltages. In a-m receivers, connect it across the second detector load resistor. In f-m receivers employing a standard Foster-Seeley discriminator preceded by a limiter stage (Fig.5), connect it across the limiter stage grid resistor R1. In f-m receivers employing a ratio detector (Fig.6), connect it across the load resistor R2 in the ratio detector circuit. Disable the agc circuit of the receiver and use battery bias, if necessary (described previously). Set an a-m receiver at a quiet point near 1600 kc and f-m receiver at a point near the low frequency end of the dial. Tune the 324 to the receiver's i-f frequency (usually 455 kc in a-m and 10.7 mc in f-m receivers) and apply the modulated output to the grid of the last i-f stage, using only enough output to produce a usable meter reading. With a proper alignment tool, adjust the output i-f transformer secondary and primary trimmers (in that order) for peak indication of the vtvm. Then move the 324 output cable to the grid of the next-to-last i-f stage and adjust the next-to-last i-f transformer secondary and primary trimmers (in that order) for peak indication of the vtvm. Finally shift the 324 output cable to the grid of the converter stage and adjust the first i-f transformer secondary and primary trimmers (in that order) for peak indication of the vtvm.

Receivers employing over-coupled i-f transformers ordinarily require that a sweep generator be used for alignment. It is possible to use the peak alignment method just described if the degree of coupling is reduced by shunting a resistor of 1000 ohms or less across the transformer winding opposite to that being tuned. That is to say, when the secondary of the transformer is being tuned, the shunt resistor is placed across the primary, and when the primary is being tuned, the shunt resistor is placed across the secondary.

F-m receivers, particularly the detector sections, are most conveniently and rapidly aligned by the visual method, using a tv-fm sweep generator such as the EICO Model 360 and an oscilloscope (any model EICO oscilloscope is suitable for this purpose). Where such equipment is not available, a careful, experienced person may do a fairly accurate alignment job with an a-m generator and a vtvm. F-m i-f alignment by the a-m generator and vtvm method is described above. F-M detector alignment by this method depends of the type of detector circuit employed in the particular receiver. Two common F-M detector circuits are diagrammed below together with the alignment instructions appropriate to each.

Fig. 4. is the basic Foster-Seeley ("phase") discriminator and preceding limiter stage. With the 324 set up and connected as per instructions for the last step of the i-f alignment shift the vtvm to measure the d-c voltage across either

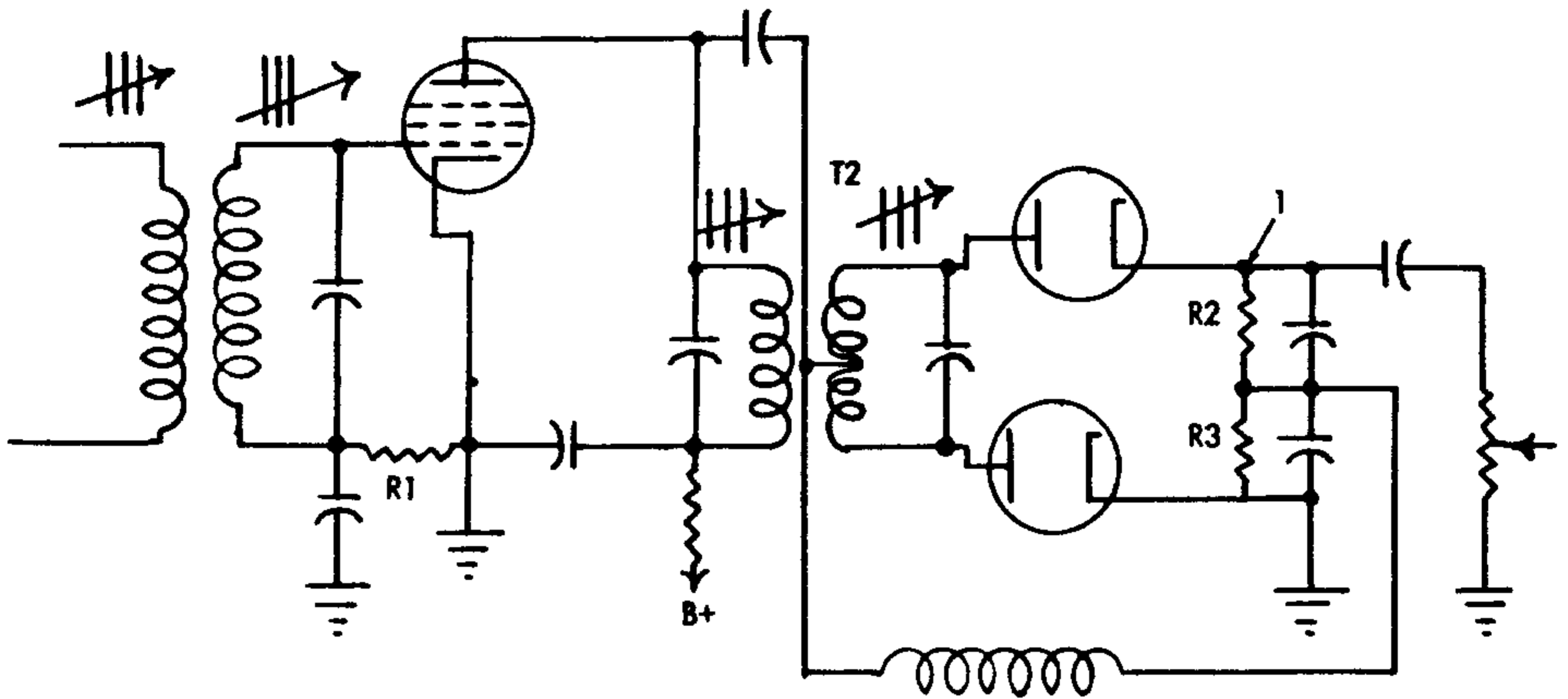

FIG. 5 BASIC FOSTER-SEELEY DISCRIMINATOR CIRCUIT

resistor R2 or R3 and adjust the primary of T2 for a maximum reading. As it is the rectified i-f frequency voltage that is being measured here, the 324 a-f modulation can be turned off for this step although it can do no harm to leave it on as some a-f modulation will filter through to the a-f section and serve to identify the signal by the loudspeaker output. Then shift the vtvm leads to measure the dc voltage across R2 and R3 in series (i.e. from point 1 to ground) and adjust the secondary of T2 until a zero reading is obtained. When using this method, set the generator to 10.7 mc as accurately as possible and what is even more important, maintain the same i-f frequency setting during all adjustments of the i-f amplifier and discriminator. (If the generator setting is slightly inaccurate it will be compensated by a slight variation in the dial setting, but a drift of only a few kc during the time between the i-f and the discriminator alignment will result in a poor job. Therefore make sure that the generator is thoroughly warmed up before doing alignment work.)

Fig. 5 is a basic ratio detector circuit. The primary circuit of T2 is realigned with an unmodulated i-f signal from the 324 connected to the same point used in the last step of the i-f alignment. Adjust the primary of T2 for peak d-c voltage reading across R2 (point 1 to ground). To align the secondary of T2 for the most usual case where R2 is a single resistor (in some receivers R2 is replaced by two equal resistors, the midpoint of which is connected to point 2 through a resistor or to ground) temporarily connect two equal resistances in series across R2 to produce artificially the condition in which the load resistance is split.





## CALIBRATION

General: Instruments purchased in kit form must be calibrated before use as described below. Factory-wired instruments have been calibrated and tested at the factory. If a change occurs in the accuracy of the instrument after a long period of use, it is probably due to aging of the components. The accuracy of the instrument may readily be restored by repeating this calibration procedure. Recalibration will also be necessary, whenever parts (tubes, etc.) are replaced.

Tuning Dial Adjustments: With the instrument out of the cabinet, insert the line cord into a 115 VAC, 50-60 cycle outlet and turn the power on. Tighten the tuning dial set screw and turn the tuning knob counter-clockwise until the tuning capacitor is fully meshed, i. e. to the point at which further counter-clockwise rotation of the tuning knob causes no further rotation of the tuning dial. Loosen the tuning dial set screw and turn the dial until zero (0) on the LINEAR REFERENCE scale appears directly under the edge-lithairline in the upper window. Retighten the tuning dial set screw.

Individual band calibration: For each of the five lowest bands there is a coil with an adjustable tuning slug mounted on the BAND SELECTOR switch. The inductance for the highest fundamental band F1 and the harmonic band F2 is simply a straight piece of heavy bus wire which provides the proper inductance at the high frequencies covered by these bands.

The coil corresponding to each band can be identified by the stock number printed on the coil form which is reproduced in the parts list with the proper identification. To facilitate calibration for the kit builder, the tuning slug in each coil has been preset at the factory so that the distance it protrudes from the coil is correct to within one-sixteenth of an inch of the value for the correct calibration.

The method of calibration is to couple the output of the signal generator to an a-m broadcast and/or short-wave receiver sufficiently to provide a strong signal of about the same strength as the broadcast stations signals to be checked against. Depending on what is expedient, the signal generator is set to read either the broadcast station carrier frequency or half the broadcast station carrier frequency (in the case of band A which is entirely below the a-m band). Then the tuning coil slug for the particular band is adjusted with a proper alignment tool until the fundamental frequency output or the second harmonic of this frequency (in the case of band A) is "zero beating" against the broadcast station carrier frequency. Approach of the "zero beat" point is indicated by a squeal heard from the radio receiver which progressively drops in pitch. The procedure is to adjust for the lowest pitched squeal or preferably, a point where there is slow popping with a rising squeal on either side of the setting. The point at which there is slow popping or complete silence is the "zero beat"

point, which means that the signal generator frequency (or a harmonic thereof) is the same as or very close to the broadcast station carrier frequency. The set-up for calibration is diagrammed in Fig. 7 below.

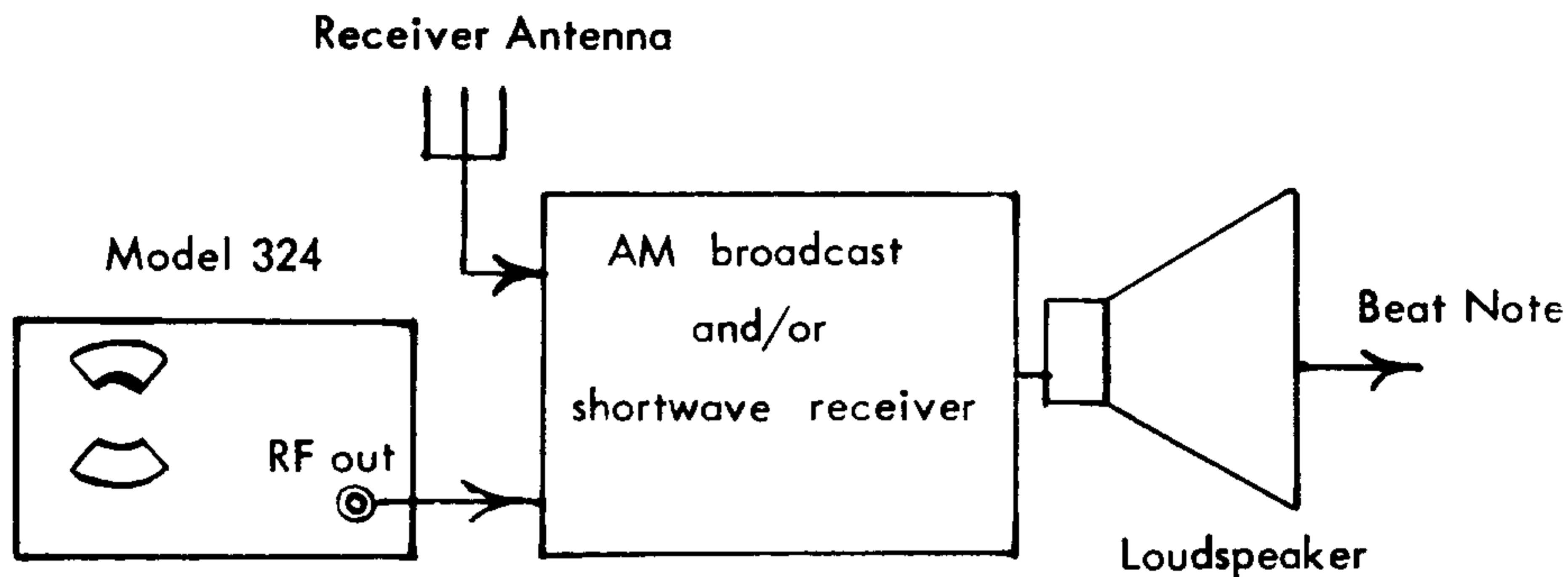

FIG. 7. SET-UP FOR 324 CALIBRATION

It is recommended that wherever possible the coil for each band be adjusted at a frequency approximately two-thirds of the frequency range up from the low end of the band.

**Band A Calibration:** Tune the receiver to a station of known frequency from 600 to 700 kc. Then set the 324 band selector switch at band A and the tuning knob to read exactly half the known broadcast station frequency. Adjust the coil A tuning slug for "zero beat". Check the calibration by setting the receiver at another station of known frequency under 800 kc and tuning the 324 through a short arc about half the known station frequency on band A to again obtain "zero beat".

**Band B Calibration:** Tune the receiver to a station of known frequency from 900 to 1000 kc. Then set the 324 band selector at band B and the tuning knob at exactly the known station frequency. Adjust the coil B tuning slug for "zero beat". Check the calibration as above.

**Band C Calibration:** If a short wave receiver is available, use can be made of the extremely accurate signals transmitted by the Bureau of Standards station WWV. This station transmits frequencies of 2.5, 5, 10, 15, 20, 25, 30, and 35 mc modulated by standard audio frequencies of 440 cps and 660 cps as well as timing signals. Transmissions on 5, 10, 15, and 20 mc are more readily received because of the high transmitting powers used. If the 2.5 mc WWV signal can be received, band C can be calibrated by setting the receiver to receive the 2.5 mc signal, setting the 324 to band C and exactly 2.5 mc on the tuning dial, and then adjusting coil C for "zero beat". If a short wave receiver is not available, calibrate band C making use of an a-m broadcast station of known frequency around 1600 kc.

**Bands D and E Calibration:** Coils D and E for bands D and E respectively can be adjusted by either zero beating against a WWV transmitted signal (5 or 10 mc for band D; 15, 20, 25, 30, or 35 mc for band E) or against a standard signal generator.

There is no calibration required for band F.

## SERVICE

If your instrument fails to function properly and the cause of the trouble can not be found, you may return it to the EICO repair department where it will be repaired at a charge of \$5.00 plus the cost of parts. (If your instrument has been built from the kit form, refer to the complete statement of the EICO servicing policy in your construction book.) Pack carefully and ship by prepaid Railway Express if possible. Return shipment will be made by express collect.

## REPLACEMENT PARTS LIST

<u>STOCK#</u>	<u>SYM.</u>	<u>DESCRIPTION</u>	<u>STOCK#</u>	<u>SYM.</u>	<u>DESCRIPTION</u>
20000	C1,2,13	cap., paper, .01 mf - 400V	51000	P1	amphenol, female
23009	C3	cap., elec., 2 X 20mf - 150V	10041	R1	res., 2.2KΩ, 1/2W, 20%
22500	C4,5	cap., disc., 1000mmf	10002	R2,3	res., 47Ω, 1/2W, 20%
22008	C6	cap., cer., 5mmf	10005	R4,5	res., 470Ω, 1/2W, 20%
22007	C7	cap., cer., 47mmf	16013	R6	pot., 200Ω (RF FINE)
20006	C8,9	cap., paper, .1mf - 400V	10040	R7	res., 68Ω, 1/2W, 20%
20001	C10	cap., paper, .05mf - 400V	10018	R8,9	res., 22KΩ, 1/2W, 20%
20008	C11	cap., paper, .02mf - 400V	10028	R10	res., 470KΩ, 1/2W, 20%
29004	C12	cap., tuning	10419	R11	res., 270KΩ, 1/2W, 10%
93003	CR1	rect., 50 ma	10424	R12	res., 22KΩ, 1/2W, 10%
92000	I1	bulb, #47	10432	R13	res., 1KΩ, 1/2W, 10%
50002	J1	amphenol, male	10410	R14	res., 100KΩ, 1/2W, 10%
52001	J2,3	binding post, 5 way	16002	R15	pot., 250KΩ (AF MOD/OUTPUT)
34501	L1	choke a.f. resonant	10012	R16	res., 4.7KΩ, 1/2W, 20%
36003	L2	coil "A"	60032	S1	switch, BAND SEL., 6 pos.
36004	L3	coil "B"	60033	S2	switch, SIGNAL SEL., 3 pos.
36005	L4	coil "C"	60034	S3	switch, RF COARSE, 3 pos.
36006	L5	coil "D"	30013	T1	transformer, power
36007	L6	coil "E"	90013	V1	12AU7 tube
36008	L7	coil "F" (straight bare wire)	90022	V2	12AV7 tube

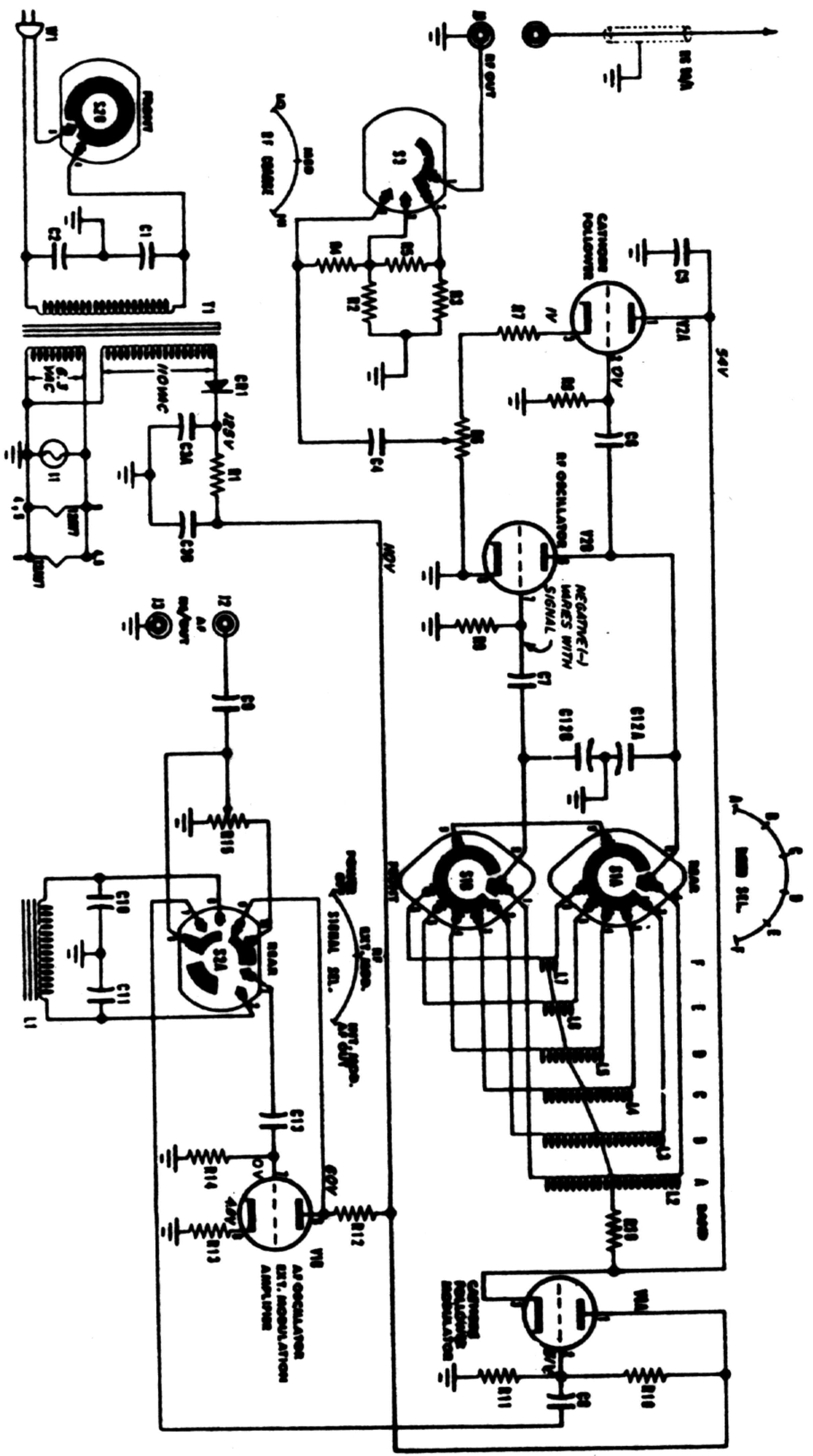

STOCK SYM.	DESCRIPTION
20000	C1,2,13 cap., paper, .01 mf-400 V
23009	C3 cap., elec., 2 X 20 mf-150 V
22500	C4,5 cap., disc., 1000 mmf
22008	C6 cap., cer., 5 mmf
22007	C7 cap., cer., 47 mmf
20006	C8,9 cap., paper, .1 mf-400 V
20001	C10 cap., paper, .05 mf-400 V
20008	C11 cap., paper, .02 mf-400 V
29004	C12 cap., tuning
93003	CR1 rect., 50 ma
92000	I1 bulb, #47
50002	J1 amphenol, male
52001	J2,3 binding post, 5 way
34501	L1 choke

STOCK SYM.	DESCRIPTION
36003	L2 coil "A"
36004	L3 coil "B"
36005	L4 coil "C"
36006	L5 coil "D"
36007	L6 coil "E"
36008	L7 coil "F" (straight bare wire)
51000	P1 amphenol, female
10041	R1 res., 2.2K $\Omega$ , 1/2 W, 20%
10002	R2,3 res., 47 $\Omega$ , 1/2 W, 20%
10005	R4,5 res., 470 $\Omega$ , 1/2 W, 20%
16013	R6 pot., 200 $\Omega$
10040	R7 res., 68 $\Omega$
10018	R8,9 res., 22K $\Omega$ , 1/2 W, 20%

STOCK SYM.	DESCRIPTION
R10	res., 470K $\Omega$ , 1/2 W, 20%
R11	res., 270K $\Omega$ , 1/2 W, 10%
R12	res., 22K $\Omega$ , 1/2 W, 10%
R13	res., 1K $\Omega$ , 1/2 W, 10%
R14	res., 100K $\Omega$ , 1/2 W, 10%
R15	pot., 250K $\Omega$
R16	res., 4.7K $\Omega$ , 1/2 W, 20%
S1	switch, BAND SEL., 6 pos.
S2	switch, SIGNAL SEL., 3 pos.
S3	switch, RF COARSE, 3 pos.
T1	transformer, power
V1	12AU7 tube
V2	12AV7 tube



# CONSTRUCTION MANUAL

## MODEL 324 SIGNAL GENERATOR

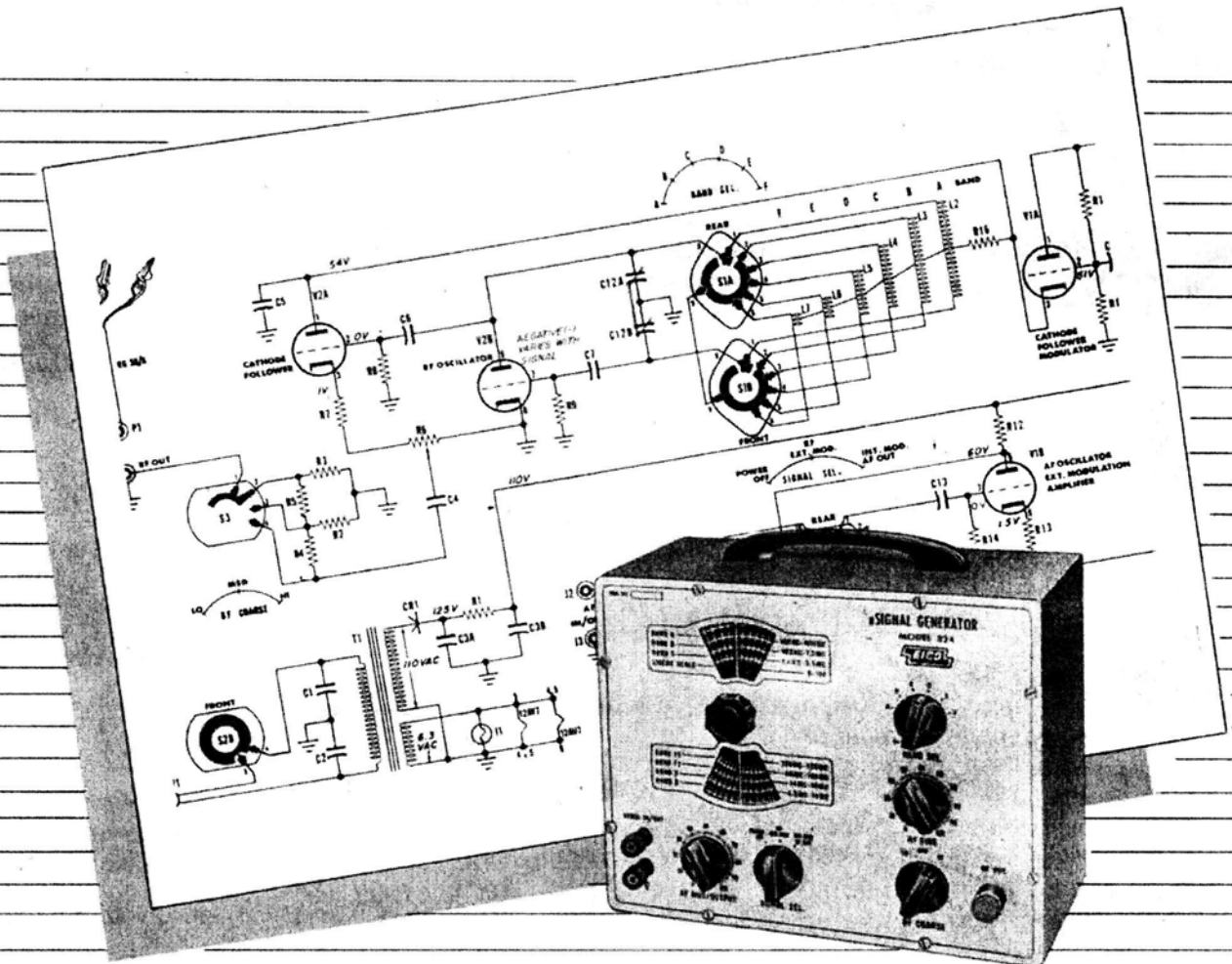

ELECTRONIC INSTRUMENT CO., Inc.

Care taken in the construction of this instrument will reward the constructor with many years of satisfactory service and greater confidence in his instrument. We urge you to not rush the construction, but to take all the time necessary for proper assembly and wiring.

Furthermore, we urge strongly that you follow the wire and parts layout shown in the pictorial diagrams as closely as possible. This is essential, because the position of wires and parts is quite critical in this instrument; changes may seriously affect the characteristics of the circuit.

**UNPACKING THE KIT:** Unpack the kit carefully and check each part against the parts list including those parts that are mounted to the chassis. If you have trouble identifying any parts, refer to the pictorial diagrams or the color code chart.

You may find that the value of a component will vary within the allowable circuit tolerance. As an example, a 470K ohm resistor may have substituted for it a 510K ohm resistor if the circuit is such as to allow this substitution. In general, resistors and controls have a tolerance of  $\pm 20\%$  unless otherwise specified. Therefore a 100K resistor may measure anywhere between 80K and 120K ohms. Tolerances on capacitors are even greater, unless specified. Limits of +100% and -50% are usual for electrolytic capacitors.

**CONSTRUCTION HINTS:** USE THE BEST GRADE OF ROSIN CORE SOLDER ONLY, preferably one containing the new activated fluxes such as Kester "Resin-Five", Ersa "Multicore" or similar types. UNDER NO CIRCUMSTANCES USE ACID CORE SOLDER OR ACID FLUX since acid flux can cause serious corrosion. Before soldering make certain of a good mechanical connection. Use a clean, freshly tinned soldering iron, no smaller than 100 watts, and place the solder on the joint (not on the iron) so that the solder is melted by the heat from the joint itself. Do not remove the soldering iron until the solder flows and check to see that the resulting joint is smooth and shiny when the solder has cooled. There are two extremes to be avoided; too little heat and too much heat. If too little heat is applied, the joint will appear pitted and grey, indicating a rosin joint which is unsatisfactory. On the other hand, if too much heat is applied to a joint, the parts connected to it may either change value, lose their protective coating, or break down. If you are soldering close to a part, hold the lead between the part and the joint being soldered with the tip of a pair of longnose pliers. The pliers will conduct the heat away and prevent the component from being unduly overheated. If for any reason it is necessary to resolder a joint, be sure to use new solder.

It should also be noted that the leads on transformers, capacitors, and resistors are very often longer than necessary. These leads should be trimmed to the proper length when wiring.

## PARTS LIST

STOCK#	SYM.	DESCRIPTION	AM'T.	STOCK#	SYM.	DESCRIPTION	AM'T.
20000	C1,2,13	cap., paper, .01 mf-400V	3	10041	R1	res., 2.2K $\Omega$ , 1/2 W, 20%	1
23009	C3	cap., elec., 2 X 20 mf-150V	1	10002	R2,3	res., 47 $\Omega$ , 1/2 W, 20%	2
22500	C4,5	cap., disc., 1000 mmf	2	10005	R4,5	res., 470 $\Omega$ , 1/2 W, 20%	2
22008	C6	cap., cer., 5 mmf	1	16013	R6	pot., 200 $\Omega$ , (RF FINE)	1
22007	C7	cap., cer., 47 mmf	1	10040	R7	res., 68 $\Omega$ , 1/2 W, 20%	1
20006	C8,9	cap., paper, .1 mf-400V	2	10018	R8,9	res., 22K $\Omega$ , 1/2 W, 20%	2
20001	C10	cap., paper, .05 mf-400V	1	10028	R10	res., 470K $\Omega$ , 1/2 W, 20%	1
20008	C11	cap., paper, .02 mf-400V	1	10419	R11	res., 270K $\Omega$ , 1/2 W, 10%	1
29004	C12	cap., tuning	1	10424	R12	res., 22K $\Omega$ , 1/2 W, 10%	1
93003	CR1	rect., 50 ma	1	10432	R13	res., 1K $\Omega$ , 1/2 W, 10%	1
92000	I1	bulb, #47	1	10410	R14	res., 100K $\Omega$ , 1/2 W, 10%	1
50002	J1	amphenol, male	1	16002	R15	pot., 250K $\Omega$ (AF MOD/OUTPUT)	1
52001	J2,3	binding post, 5 way	2	10012	R16	res., 4.7K $\Omega$ , 1/2 W, 20%	1
34501	L1	choke a.f. resonant	1	60032	S1	switch, BAND SEL., 6 pos.	1
36003	L2	coil "A"	1	60033	S2	switch, SIGNAL SEL., 3 pos.	1
36004	L3	coil "B"	1	60034	S3	switch, RF COARSE, 3 pos.	1
36005	L4	coil "C"	1	30013	T1	transformer, power	1
36006	L5	coil "D"	1	54011	TB1	term. post, 1 post dual lug, vertical	1
36007	L6	coil "E"	1	54003	TB2	term. post, 2 post	1
36008	L7	coil "F" (straight bare wire)	1	54002	TB3	term. post, 1 post right w/gnd.	1
51000	P1	amphenol, female	1	90013	V1	12AU7 tube	1

<u>STOCK#</u>	<u>SYM.</u>	<u>DESCRIPTION</u>	<u>AM'T.</u>	<u>STOCK#</u>	<u>SYM.</u>	<u>DESCRIPTION</u>	<u>AM'T.</u>
90022	V2	12AV7 tube	1	58300		spaghetti	pc.
97707	X11	pilot lite assembly	1	41006		screw, 10-24 X 3/8	2
97025	XV1,2	tube socket, 9 pin miniature	2	41035		screw, self-tapping, #6 P.K.	9
57000		line cord	1	40001		nut, hex, 3/8"	11
80039		panel	1	42000		washer, lock, 3/8"	5
89543		dial plate w/bushing	1	42001		washer, flat, 3/8"	6
81059		chassis	1	43001		ground lug, 3/8"	3
81060		subchassis	1	42018		washer, fibre shoulder, #8	2
88021		cabinet	1	42017		washer, fibre flat, #8	1
87000		handle	1	42008		washer, lock, #8	2
46005		rubber foot	4	43004		lug, #8	1
46000		grommet, 3/8"	1	40008		nut, hex, #8	3
89534		plastic window	1	41016		screw, 4-40 X 1/4	4
53006		knob, round bar	5	40007		nut, hex, 4-40	4
53003		knob, small tuning (scalloped rim)	1	41010		screw, 6-32 X 1/8	3
51502		crocodile clip	2	41000		screw, 6-32 X 1/4	6
58000		hook-up wire	pc.	40000		nut, hex, #6	7
58405		cable, 50 $\Omega$	4 ft.	43000		ground lug, #6	4
58500		bare wire, #14	pc.	42002		washer, lock, #6	6
58501		bare wire, #22	pc.	85001		bushing, 1/4 I.D.	1
58301		heavy tubing	pc.	66008		instruction book	1
				66258		construction book	1

NOTE: When ordering replacement parts, please include all of the following information: 1) stock number and description given in parts list; 2) quantity; 3) model number of instrument; 4) serial number of instrument (on panel). This information will expedite the processing of your order and insure your receiving the correct replacement parts.

## CONSTRUCTION PROCEDURE

**CONSTRUCTION PROCEDURE:** The step-by-step mounting and wiring procedure given below allows you to complete the mounting and wiring in a systematic manner. When you have completed a mounting or wiring instruction, check it off in the space provided. The method and location of mounting or the proper way to run a particular lead is shown in the accompanying drawings. To keep the drawings uncrowded, unnecessary repetition of mounting or wiring details may be omitted.

**NOTE:** In some cases, more than one connection is made to the same terminal. This condition is designated in the wiring instructions by the abbreviation (C), meaning that the connection should not be soldered until other leads have been connected. Where only one lead is connected to a terminal, or where the last of several leads is connected, the abbreviation (S) will be given. (S) means that the joint should be soldered.

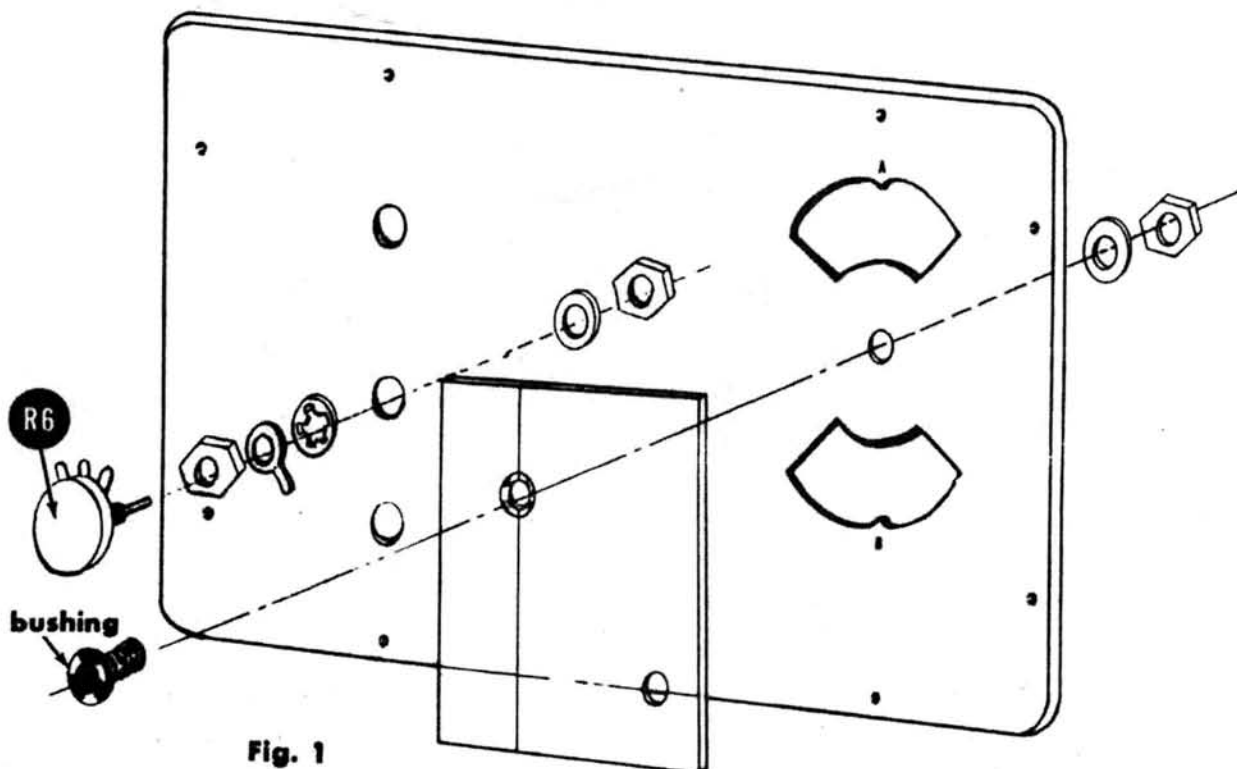

Fig. 1

- ( ) Fig. 1. Mount the plexiglass window to the panel with the bushing, 1-3/8 flat washer, and 1-3/8 hex nut. Note that the hole in the window used for mounting is counterbored to accept the bushing and that the panel lamp hole in the window is at the lower right in the rear view. Note also that there is a scribed hairline on the back surface of the window which passes through the center of the mounting hole. Before tightening the nut, line up the window so that both indicating points A & B on the panel lie directly over the hairline.
- ( ) Fig. 1. Mount the RF FINE potentiometer R6 (200Ω) to the panel, using 2-3/8 hex nuts, 1-3/8 ground lug, 1-3/8 lock washer, and 1-3/8 panel washer.
- ( ) Fig. 2. Mount the power transformer T1 to the chassis. Along with it mount the 2X20 electrolytic capacitor C3 and the 1 post right w/gnd terminal strip TB3. Use 2 #6-32 X 1/4 screws, 2 #6 lock washers, and 2 #6 hex nuts.
- ( ) Fig. 2. Mount the selenium rectifier CR1, positioning it with the positive terminal as shown. Use 1 #6 lock washer, and 1 #6 hex nut.
- ( ) Fig. 2. Mount the 9-pin miniature socket XV1, positioning it with the blank (no pin) sector as shown. Along with it mount terminal strip TB1 (double lug - not grounded). Use 2 #4-40 X 1/4 screws, 2 #4-40 hex nuts, 1 lock washer, and 1 ground lug.
- ( ) Fig. 2. Mount a.f. resonating choke L1 to the chassis, first passing the 2 black leads through hole "X". Along with it mount the 2 post terminal strip TB2. Use 2 #6-32 X 1/4 screws, 2 #6-32 hex nuts, 1 #6 lock washer, and 1 ground lug.



The following five steps accomplish the mounting of the chassis to the panel.

- ( ) Fig. 2. Mount the male amphenol connector J1 (RF OUT) to panel and chassis using the hardware shown.
- ( ) Fig. 2. Mount the 250K $\Omega$  AF/MOD OUT potentiometer R15 to panel and chassis, using 2 - 3/8 hex nuts, 1 - 3/8 lock washer, 1 ground lug, and 1 panel washer. The inside hex nut should be used as a back-up nut so that the potentiometer bushing does not extend past the outside nut.
- ( ) Fig. 2. Mount the RF COARSE switch S3 to panel and chassis using the same hardware as above including the ground lug. Note the positioning of S3 in the drawing and observe it in the mounting. Do not tighten outside hex nut finally as yet.
- ( ) Fig. 2. Mount the SIGNAL SEL. switch S2 to panel and chassis using the same hardware as above but no ground lug. Note the position of S2 in the drawing and observe it in the mounting. Here also do not tighten the outside hex nut

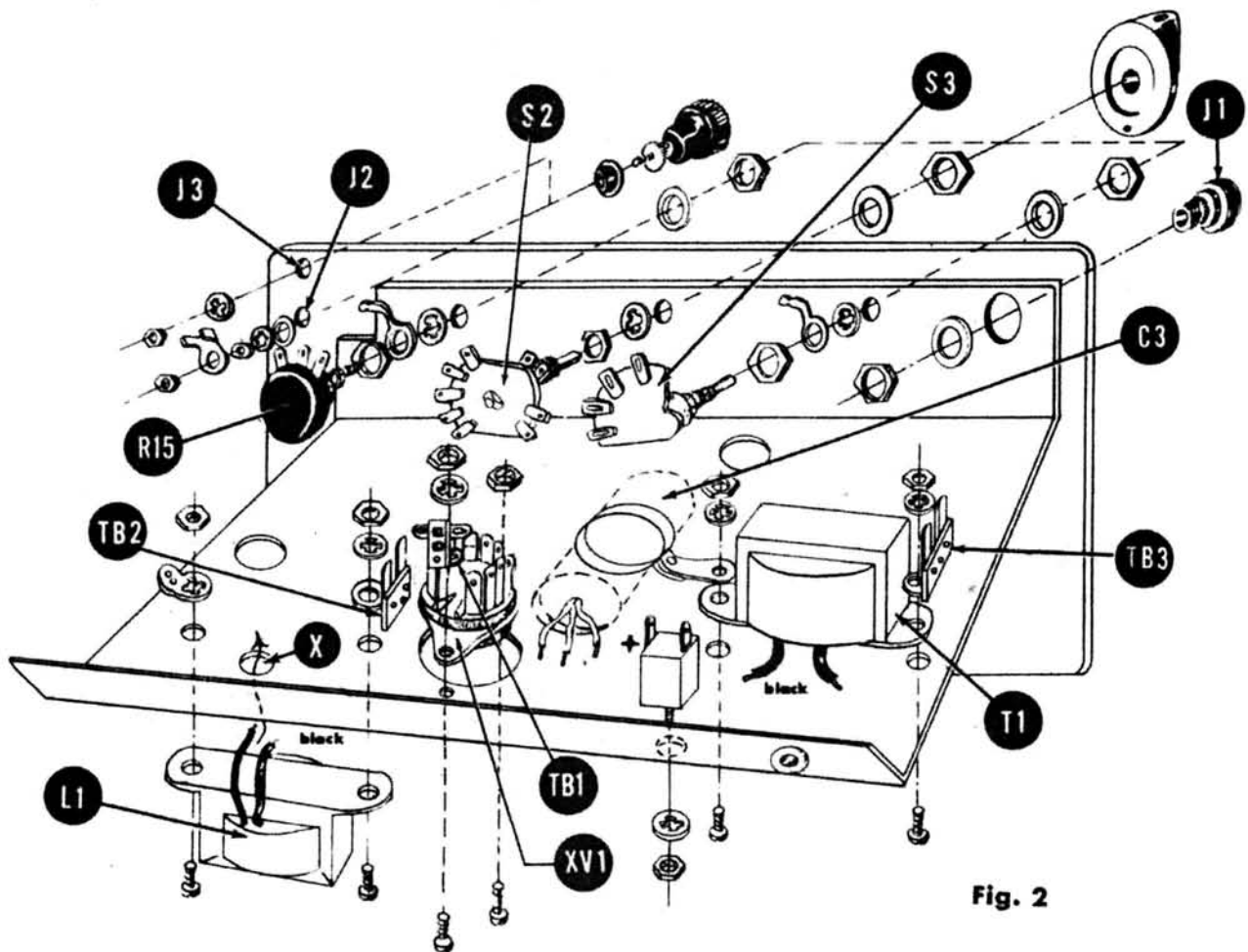

Fig. 2

- ( ) Fig. 2. Place the panel and chassis on its side. Use a pair of pliers to turn the shafts of both the SIGNAL SEL. switch S2 and the RF COARSE switch S3 to the furthest counter-clockwise position. Next orient switch S2 so that the flat on the shaft faces away from the POWER OFF position and tighten the panel nut finally. Now orient switch S3 so that the flat on the shaft faces away from the LO position and then tighten the S3 panel nut finally. The assembly of panel to chassis is now completed.
- ( ) Fig. 2. Mount the AF IN/OUT binding posts J2 and J3 on the panel. Note that J2 is insulated from the panel and that J3 is not insulated. Use 1 #8 fibre shoulder washer (for insulation), 1 #8 fibre flat washer, 1 #8 lock washer, 1 #8 lug, and 2 #8 hex nuts to mount J2 and the same hardware less the fibre flat washer and the lug to mount J3.
- ( ) Fig. 2. Install the 3/8" rubber grommet in the hole provided in the rear chassis apron. Squeeze the grommet into oval shape to start it in the hole and then work it in completely with a small screwdriver.

- ( ) Fig. 3. Mount the tuning capacitor C12 to the sub-assembly bracket using 3 #6-32 X 1/8 screws. To protect C12 during this operation, turn the shaft fully counter-clockwise so that the rotor and stator are fully meshed.
- ( ) Fig. 3. Mount the 9-pin min. socket XV2 on the sub-assembly bracket using 2 #4-40 X 1/4 screws, 2 #4-40 hex nuts, and 2 ground lugs. Orient the socket with the blank (no pin) sector as shown in the drawing.
- ( ) Fig. 4. Connect a 22K $\Omega$  resistor, R8 from XV2-2 (C) to XV2-8 (C).
- ( ) Fig. 4. Connect a short length of bare wire from XV2-8 (S) to ground lug A (C).
- ( ) Fig. 4. Connect a 1000 mmf capacitor C5 from XV2-1 (C) to ground lug A (S).
- ( ) Fig. 4. Connect the 5 mmf capacitor C6 from XV2-2 (S) to XV2-6 (C).
- ( ) Fig. 4. Connect a short length of bare wire from XV2-6 (S) to C12A (C).
- ( ) Fig. 4. Connect a short length of bare wire from XV2-4 (S), thru XV2-5 (S) to ground lug B (C).
- ( ) Fig. 4. Connect the other 22K resistor R9 from ground lug B (S) to XV2-7 (C).
- ( ) Fig. 4. Connect the 47 mmf capacitor C7 from XV2-7 (S) to C12B (C).

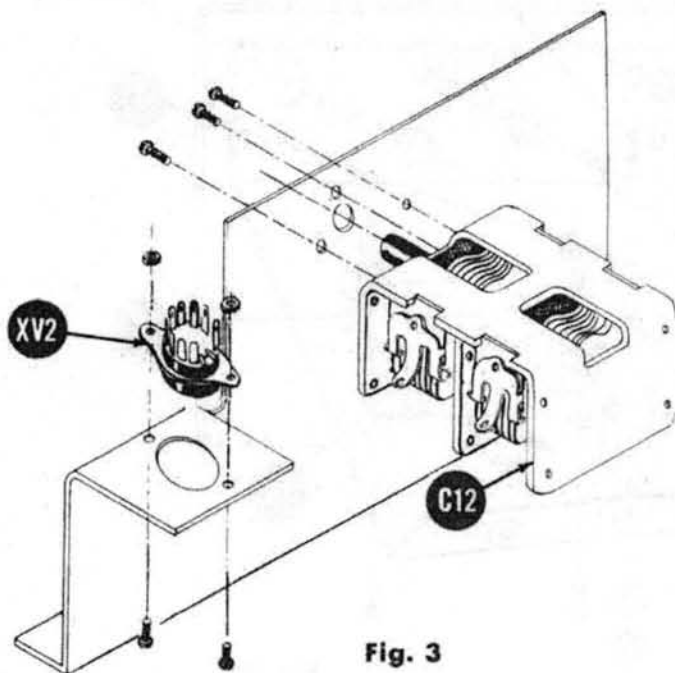

Fig. 3

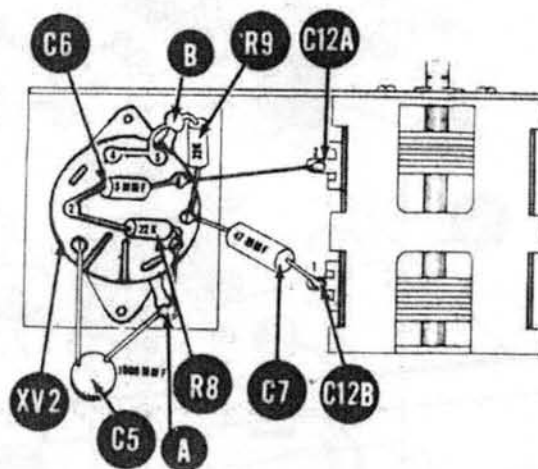

Fig. 4

#### PREWIRING OF BAND SELECTOR SWITCH S1

Prewire band switch S1 as shown in Fig. 5 (rear view). As S1 is the only two-wafer switch in the kit, it cannot be mistaken. The wafer nearest the knob end is designated as section A and the other wafer as section B. Coils L2 to L6 and the length of bus bar which at the high frequencies of band F acts as inductance L7 are wired between corresponding terminals on the two wafers as shown.

In order to do this job properly, examine any one of the coils and note that there are three terminals, numbered 1, 2, and 3 on the insert drawing of Fig. 5. Terminal 1 (nearest the tuning slug) is one end of the coil, terminal 3 is the other end of the coil, and terminal 2 is the tap on the coil. The wafers of S1 are spaced the same distance as coil terminals 1 and 3 so that each coil can be conveniently connected between corresponding terminals on each wafer. Please observe the following precautions when wiring in the coils, as otherwise one or more coils may be irreparably damaged: 1) Take care that your soldering iron does not accidentally come in contact with any coil; 2) Do not overheat any coil terminal (solder quickly with a hot iron using a minimum amount of solder); 3) Do not attempt to move any coil terminal as it may result in breaking the connection to the coil.

Each of the wound coils can be readily identified by the stock number which is referred to in the step-by-step wiring instructions that follow.

- ( ) Fig. 5. Place coil L2 (stock# 36003) on switch S1 so that L2#1 rests on S1B#1 and L2#3 rests on S1A#1. Solder L2#1 to S1B#1 and L2#3 to S1A#1.
- ( ) Fig. 5. Similarly position coil L3 (stock# 36004) on the S1B#2 and S1A#2 terminals of S1. Solder L3#1 to S1B#2 and L3#3 to S1A#2.
- ( ) Fig. 5. Similarly position coil L4 (stock# 36005) on the S1B#3 and S1A#3 terminals of S1. Solder L4#1 to S1B#3 and L4#3 to S1A#3.
- ( ) Fig. 5. Similarly position coil L5 (stock# 36006) on the S1B#4 and S1A#4 terminals of S1. Solder L5#1 to S1B#4 and L5#3 to S1A#4.
- ( ) Fig. 5. Similarly position coil L6 (stock# 36007) on the S1B#5 and S1A#5 terminals of S1. Solder L6#1 to S1B#5 and L6#2 to S1A#5.
- ( ) Fig. 5. Connect S1B#6 and S1A#6 with a straight piece of heavy bus bar, soldering at both terminals. Trim off any excess. At the high frequency range of band F, this piece of wire acts as an inductance and is therefore designated as L7.
- ( ) Fig. 5. Connect and solder a short length of bare wire from S1B#9 to S1A#9.
- ( ) Fig. 5. Connect and solder one end of a length of bare wire to the mid-point of the bus bar designated as L7. In turn connect this wire to L6#2 (S), L5#2 (S), L4#2 (S), L3#2 (S), and L2#2 (C).
- ( ) Fig. 5. Connect one lead of the 4.7KΩ resistor R16 to L2#2 (S).

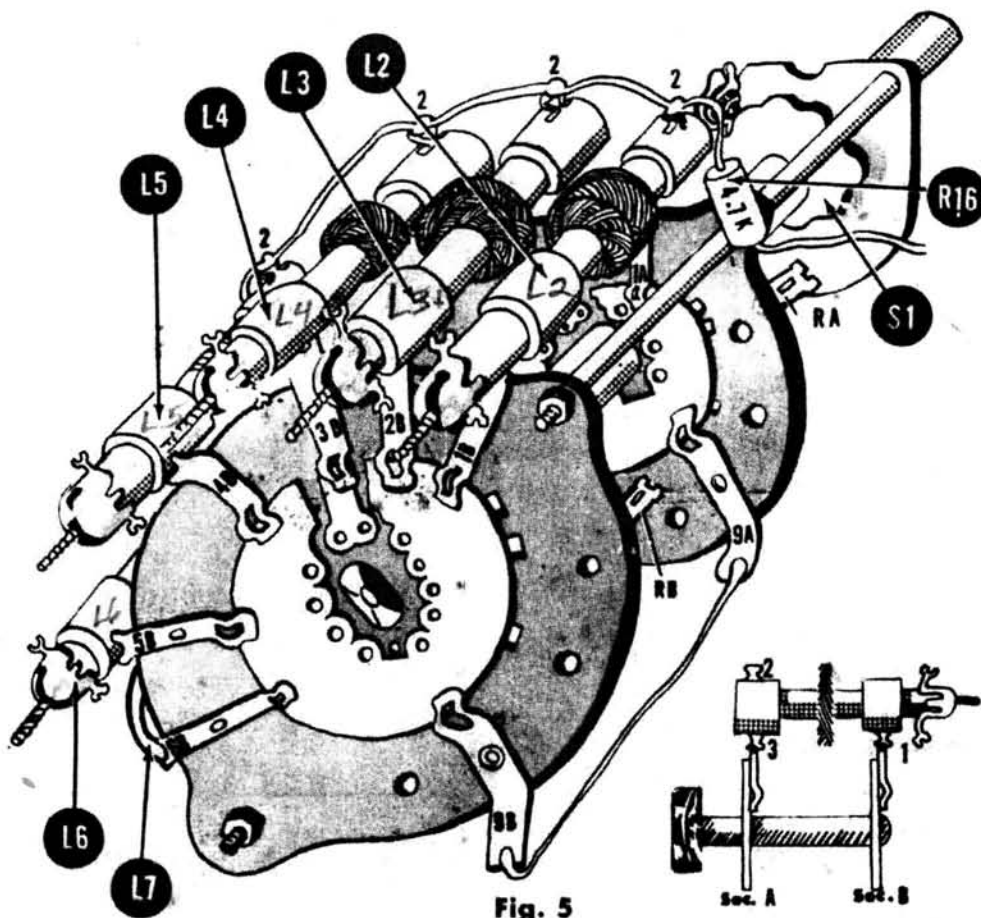
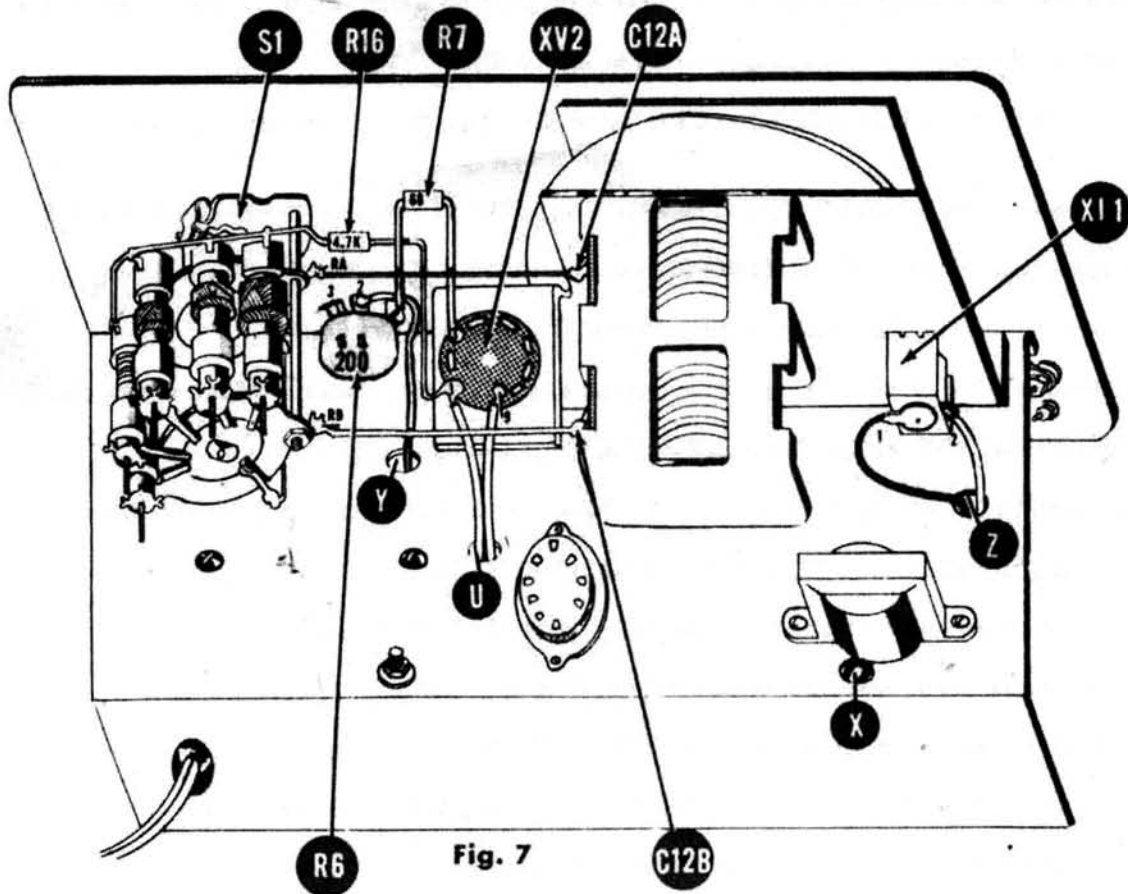

Fig. 5



- ( ) Fig. 6. Connect a .01 mf capacitor C2 from TB3-1 (S) to TB3-2 (C).
- ( ) Fig. 6. Connect the other red lead of power transformer T1 to the negative terminal of the selenium rectifier CR-2 (S).
- ( ) Fig. 6. Connect one black lead of power transformer T1 to TB3-2 (C).
- ( ) Fig. 6. Connect the other black lead of power transformer T1 to switch terminal S2-4 (C).
- ( ) Fig. 6. Connect one red lead of the dual 20 mfd capacitor C3 to the positive terminal of the selenium rectifier CR1-1 (C).
- ( ) Fig. 6. Connect the 2.2K $\Omega$  resistor R1 from CR1-1 (S) to TB1-1B (C). Note that terminal strip TB1 has one insulated double lug. For reference purposes, the end of the double lug nearest selenium rectifier CR1 is designated as TB1-1B and the opposite end is designated as TB1-1A. The metal foot by which TB1 is mounted is designated as TB1-2.
- ( ) Fig. 6. Connect the other red lead of capacitor C3 to TB1-1B (C).
- ( ) Fig. 6. Connect the black lead of capacitor C3 to TB1-2 (C). Lug TB1-2 is the metal foot by which TB1 terminal is mounted.
- ( ) Fig. 6. Connect one end of a 6 in. piece of hook-up wire to XV1-3 (S). Pass the other end thru chassis hole "U".
- ( ) Fig. 6. Connect one end of a 6 in. piece of hook-up wire to XV1-5 (C). Pass the other end thru chassis hole "U".
- ( ) Fig. 6. Connect a short piece of bare wire from XV1-5 (S) to XV1-4 (C).
- ( ) Fig. 6. Connect one end of a 6 in. piece of hook-up wire to XV1-4 (S). Pass the other end thru chassis hole "Z".
- ( ) Fig. 6. Connect the 100K $\Omega$  resistor R14 from XV1-7 (C) to ground lug D (C).
- ( ) Fig. 6. Connect the .01 mf capacitor C13 from XV1-7 (S) to S2-1 (S). Use spaghetti on both leads.
- ( ) Fig. 6. Connect the 1K $\Omega$  resistor R13 from XV1-8 (S) to XV1-9 (C).
- ( ) Fig. 6. Connect a short length of bare wire from XV1-9 (S) to TB1-2 (S) (ground).
- ( ) Fig. 6. Connect a length of hook-up wire from XV1-6 (C) to S2-9 (S).
- ( ) Fig. 6. Connect the 22K $\Omega$  resistor R12 from XV1-6 (S) to TB1-1B (S).
- ( ) Fig. 6. Connect a .01 mf capacitor C1 from S2-4 (S) to ground lug D (C). Use spaghetti.
- ( ) Fig. 6. Connect the 270K $\Omega$  resistor R11 from ground lug D (S) to XV1-2 (C).
- ( ) Fig. 6. Connect a .1 mf capacitor C8 from XV1-2 (C) to S2-7 (S). Use spaghetti.
- ( ) Fig. 6. Connect the 470K $\Omega$  resistor R10 from XV1-2 (S) to TB1-1A (C).
- ( ) Fig. 6. Connect a short length of bare wire from XV1-1 (S) to TB1-1A (S).
- ( ) Fig. 6. Connect one of the black leads of a.f. resonant choke L1 (emerging from chassis hole "X") to TB2-1 (C).
- ( ) Fig. 6. Connect other black lead of choke L1 to TB2-2 (C).
- ( ) Fig. 6. Connect the .05 mf capacitor C10 from TB2-1 (C) to ground lug E (C).
- ( ) Fig. 6. Connect a length of hook-up wire from TB2-1 (S) to S2-8 (S).
- ( ) Fig. 6. Connect the .02 mf capacitor C11 from TB2-2 (C) to ground lug E (C).
- ( ) Fig. 6. Connect a length of hook-up wire from TB2-2 (S) to S2-2 (S).

- ( ) Fig. 6. Connect one end of a 3 in. length of hook-up wire to ground lug E (S) and pass the other end thru chassis hole "Z".
- ( ) Fig. 6. Connect a length of hook-up wire from S2-10 (S) to potentiometer R15-1 (S).
- ( ) Fig. 6. Connect a length of hook-up wire from S2-6 (S) to R15-2 (C).
- ( ) Fig. 6. Connect the .1 mf capacitor C9 from R15-2 (S) to binding post J2 (S). Use spaghetti.
- ( ) Fig. 6. Solder the ground lug mounted behind potentiometer R15 to terminal #3 of R15.
- ( ) Fig. 6. Pass the stripped end of the line cord through the grommet previously installed in the rear chassis apron and knot it 6 in. from the stripped ends. Connect one lead of the line cord to TB3-2 (S) and the other lead to S2-5 (S).



- ( ) Fig. 7. Mount the scale dial on the outer shaft of the tuning capacitor. (The dial will be adjusted to the proper position when the unit is calibrated.)
- ( ) Fig. 7. Mount the prewired sub-chassis to the main chassis using 2 #6-32 X 1/4 screws, 2 #6 hex nuts, and 2 #6 lock-washers.
- ( ) Fig. 7. Connect the 68Ω resistor R7 from XV2-3 (S) to RF FINE pot. R6-1 (S). Use spaghetti.
- ( ) Fig. 7. Connect the other end of the 1000 mmf capacitor C4 emerging from hole "Y" to R6-2 (S). Use spaghetti.
- ( ) Fig. 7. Solder the ground lug mounted behind potentiometer R6 to R6-3 (S).
- ( ) Fig. 7. Mount the prewired Band Sel switch S1 to the panel. Use 2-3/8 hex nuts, 1-3/8 lock washers and 1-3/8 flat washer. Switch S1 is shown in approximately the correct position in the drawing. Before tightening the outside hex nut, use a pair of pliers to turn the shaft to the farthest counter-clockwise position and then orient the switch so that the flat on the shaft faces away from the A band position.

- ( ) Fig. 7. Connect the lead coming from XV1-5 and emerging from hole "U" to XV2-9 (S).
- ( ) Fig. 7. Connect the lead coming from XV1-3 and emerging from hole "U" to XV2-1 (C).
- ( ) Fig. 7. Connect the free lead of the 4.7K $\Omega$  resistor R16 coming off L2#2 to XV2-1 (S).
- ( ) Fig. 7. Connect a straight length of heavy bus bar from S1-RA (S) to C12A (S).
- ( ) Fig. 7. Connect a straight length of heavy bus bar from S1-RB (S) to C12B (S).
- ( ) Fig. 7. Insert the #47 pilot lamp I1 in the holder X11 and slip the 5/8" length of tubing over the bulb. Compress the holder and insert the bulb in the sub-chassis hole so that the exposed bulb tip enters the hole in the plexiglass.
- ( ) Fig. 7. Connect the lead coming from XV1-4 and emerging from hole "Z" to X11-2 (S).
- ( ) Fig. 7. Connect the lead coming from ground lug E and emerging from hole "Z" to X11-1 (S).

### PREPARATION OF RF OUTPUT CABLE

- ( ) Figs. 8 & 9 Connect the female co-axial connector to one end of the length of co-axial cable provided as follows: Strip the cable end exactly as shown in Fig. 8. Disassemble the connector. As shown in Fig. 9, slip the stripped cable end into the larger diameter end of the spring and then solder the small diameter end of the spring to the very edge of the metal braid. Slip the connector ring over the cable end past the spring, unthreaded end first. Pass the cable end thru the tapered end of the connector (threading the inner conductor thru the eyelet in the bakelite disc) until passage is stopped by the larger spring diameter. Tighten the set screw in the connector body so that the cable and spring will be secured mechanically. Solder the inner conductor of the cable to the eyelet in the bakelite disc and trim off excess lead. A section of the internally threaded part of the connector ring should extend past the connector body to enable coupling to the male connector on the panel. Complete the opposite end of the cable as follows: Strip away 3 1/2" of outer insulation and 3" of the outer braid. Cut off 4" of stranded wire and strip off 1/2" of insulation from one end. Wrap the stripped end around the exposed cable braid and solder, being careful not to over-heat the cable. Finally connect and solder a crocodile clip to the opposite end of this lead and to the inner conductor of the co-axial cable.

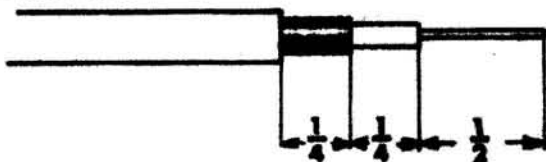

Fig. 8



Fig. 9

### FINAL STEPS

You have now completed the assembly and wiring of your instrument. When you have completed the following steps, your instrument will be ready for use.

- 1) Make a careful examination of the unit to determine whether all joints are soldered properly. Check for loose lumps of solder and straighten out the wiring and components so that there are no accidental shorts.
- 2) The flowing of rosin between switch contacts causes leakage. If examination reveals the presence of rosin, remove it by briskly cleaning the area between the contacts with a stiff brush saturated with carbon tetrachloride. Be very careful not to spring the contacts when cleaning switches.
- 3) Insert the 12AU7 tube V1 into tube socket XV1 on the chassis.
- 4) Insert the 12AV7 tube V2 into tube socket XV2 on the sub-assembly bracket.
- 5) Mount the tuning knob (scalloped rim) on the shaft of the tuning capacitor and tighten the set screw.
- 6) Turn the shafts of the RF FINE and AF MOD/OUTPUT controls maximum counter-clockwise. Mount a knob on each shaft and tighten the set screw with the knob pointing at zero (0) on the dial in both cases.

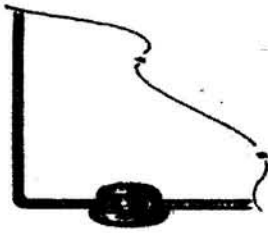

Fig. 10

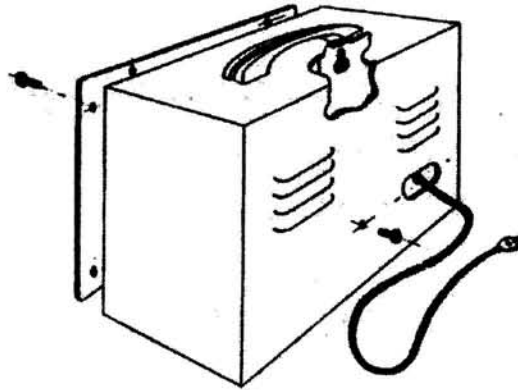

Fig. 11

7) Place knobs on the RF COARSE, BAND SEL., and SIGNAL SEL. switches. In each case, tighten the set screw against the flat on each switch shaft. If the assembly instructions given previously were followed correctly, each knob should then point at the furthest counter-clockwise position on each dial.

8) Before connecting the instrument to the a-c line, connect an ohmmeter from B plus (positive terminal CR1) to ground (chassis). The resistance should not be less than 200,000 ohms. (NOTE: wait until the ohmmeter reading reaches the final value.) If the resistance is under 200,000 ohms, do not connect to the a-c line before you have checked the rectifier circuit and remedied the trouble.

9) Position the tuning dial and calibrate the instrument as described in the Instruction Book.

10) Insert the rubber feet in the openings provided in the bottom of the cabinet as shown. The method is to work the rounded portion of each foot into the interior of the cabinet from the outside, using a small screwdriver. The flat portion should be the actual resting or contact surface. See Insert drawing of Fig. 10.

11) Mount the handle on the cabinet with two #10-24 screws as shown in Fig. 11.

12) Run the a-c line cord through the rear cabinet opening and insert the completed unit in the cabinet. Align the hole in the cabinet rear and the hole in the rear chassis apron and insert 1 #6 P.K. screw. Then align the 8 panel holes with the corresponding holes in the cabinet flange and insert 8 #6 P.K. screws. Tighten all screws. See Fig. 11.

#### NOTE

If the instrument fails to operate properly, recheck the wiring for errors or reversed connections, test for continuity, and check individual components for breakdown. Check all dc and ac operating voltages, keeping in mind that all voltages may vary from the values shown by as much as 15% due to component tolerance, line voltage variations, and type of measuring instrument used (schematic voltages were measured with VTVM).

#### SERVICE

If you are still having difficulty, write to our service department listing all possible indications that might be helpful. If desired, you may return the instrument to our factory where it will be placed in operating condition for \$5.00 plus the cost of parts replaced due to their being damaged in the course of construction. This service policy applies only to completed instruments constructed in accordance with the instructions as stated in the manual. Instruments that are not completed or instruments that are modified will not be accepted for repair. Instruments that show evidence of acid core solder or paste fluxes will be returned, not repaired. **NOTE:** Before returning this unit, be sure all parts are securely mounted. Attach a tag to the instrument, giving your home address and the trouble with the unit. Pack very carefully in a rugged container, using sufficient packing material (cotton, shredded newspaper, or excelsior), to make the unit completely immovable within the container. The original shipping carton is satisfactory, providing the original inserts are used or sufficient packing material is inserted to keep the instrument immovable. Ship by prepaid Railway Express, if possible, to the Electronic Instrument Co., Inc. 33-00 Northern Blvd., Long Island City 1, New York. Return shipment will be made by express collect. Note that a carrier cannot be held liable for damages in transit if packing, IN HIS OPINION, is insufficient.



# RESISTOR COLOR CODES

**RMA COLOR CODE FOR  
FIXED COMPOSITION RESISTORS**

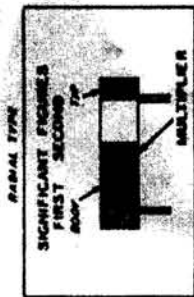
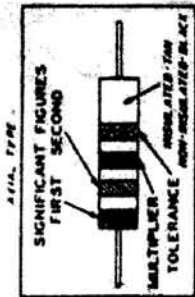

**JAN COLOR CODE FOR  
FIXED COMPOSITION RESISTORS**



# CAPACITOR COLOR CODES

**RMA 3-DOT COLOR CODE FOR MICA-DIELECTRIC CAPACITORS**

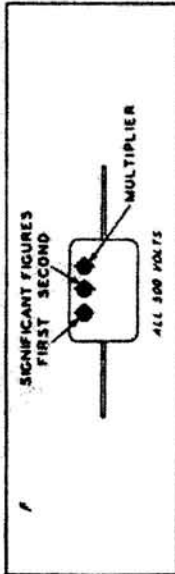

**JAN 8-DOT COLOR CODE FOR PAPER-DIELECTRIC CAPACITORS**

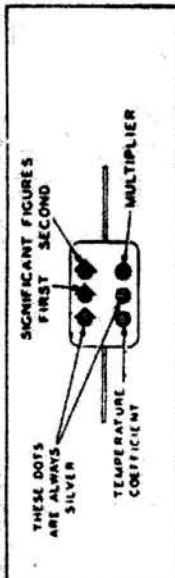

**RMA 8-DOT COLOR CODE FOR MICA-DIELECTRIC CAPACITORS**

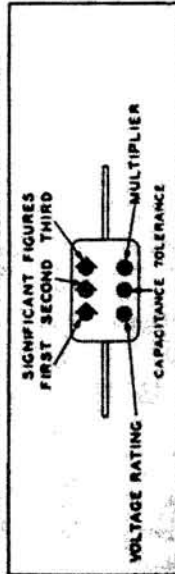

**JAN 8-DOT COLOR CODE FOR MICA-DIELECTRIC CAPACITORS**

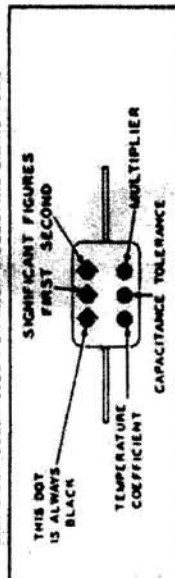

**RMA COLOR CODE FOR TUBULAR  
CERAMIC-DIELECTRIC CAPACITORS**

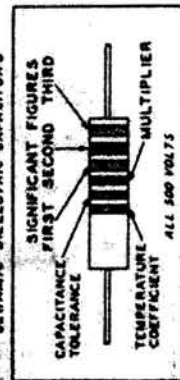

**JAN COLOR CODE FOR FIXED CERAMIC-DIELECTRIC CAPACITORS**

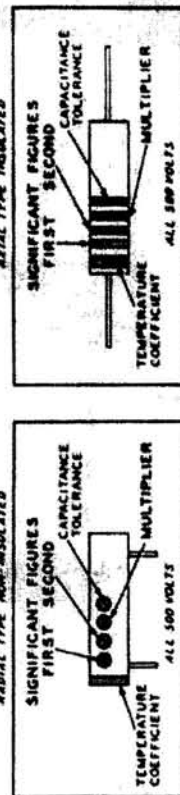

**AXIAL TYPE INSULATED**

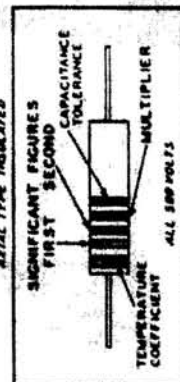

RMA: RADIO MANUFACTURERS ASSOCIATION  
JAN: JOINT ARMY-NAVY

RESISTORS		CAPACITORS							
TOLERANCE	MULTIPLIER	SIGNIFICANT FIGURE	COLOR	AXIAL TYPE NON-INSULATED	JAN MICA AND PAPER-DIELECTRIC	MULTIPLIER	JAN CERAMIC DIELECTRIC	VOLTAGE RATING	TEMPERATURE COEFFICIENT
5	0.1	0	BLACK	1	1	1	1	1	A
10	0.01	1	BROWN	10	10	10	10	100	B
20		2	RED	100	100	100	100	200	C
		3	ORANGE	1000	1000	1000	1000	300	D
		4	YELLOW	10000	10000	10000	10000	400	E
		5	GREEN	100000	100000	100000	100000	500	F
		6	BLUE	1000000	1000000	1000000	1000000	600	G
		7	VIOLET	10000000	10000000	10000000	10000000	700	
		8	GRAY	100000000	100000000	100000000	100000000	800	
		9	WHITE	1000000000	1000000000	1000000000	1000000000	900	
			GOLD	0.1	0.1	0.1	0.1	1000	
			SILVER	0.01	0.01	0.01	0.01	2000	
			NO COLOR					500	

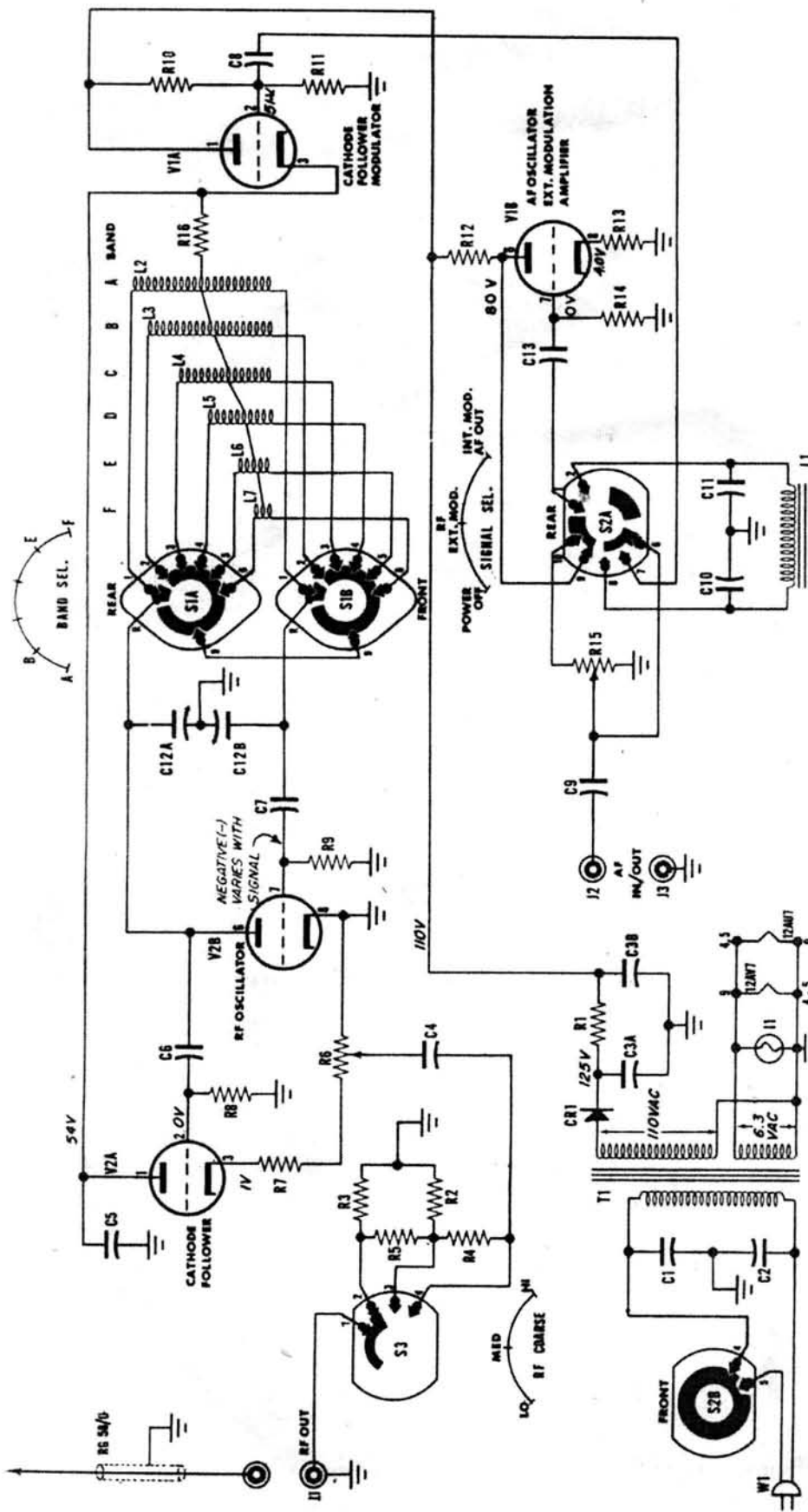

STOCK #	SYM.	DESCRIPTION	STOCK #	SYM.	DESCRIPTION	STOCK #	SYM.	DESCRIPTION
20000	C1,2,13	cap., paper, .01 mf-400V	36003	L2	coil "A"	10028	R10	res., 470K $\Omega$ , 1/2 W, 20%
23009	C3	cap., elec., 2 X 20 mf-150V	36004	L3	coil "B"	10419	R11	res., 270K $\Omega$ , 1/2 W, 10%
22500	C4,5	cap., disc., 1000 mfmf	36005	L4	coil "C"	10424	R12	res., 22K $\Omega$ , 1/2 W, 10%
22008	C6	cap., cer., 5 mfmf	36006	L5	coil "D"	10432	R13	res., 1K $\Omega$ , 1/2 W, 10%
22007	C7	cap., cer., 47 mfmf	36007	L6	coil "E"	10410	R14	res., 100K $\Omega$ , 1/2 W, 10%
20006	C8,9	cap., paper, .1 mf-400V	36008	L7	coil "F" (straight bare wire)	16002	R15	pot., 250K $\Omega$
20001	C10	cap., paper, .05 mf-400V	51000	P1	amphenol, female	10012	R16	res., 4.7K $\Omega$ , 1/2 W, 20%
20008	C11	cap., paper, .02 mf-400V	10041	R1	res., 2.2K $\Omega$ , 1/2 W, 20%	60032	S1	switch, BAND SEL., 6 pos.
29004	C12	cap., tuning	10002	R2,3	res., 47 $\Omega$	60033	S2	switch, SIGNAL SEL., 3 pos.
93003	CR1	rect., 50 ma	10005	R4,5	res., 470 $\Omega$ , 1/2 W, 20%	60034	S3	switch, RF COARSE, 3 pos.
92000	I1	bulb, #47	16013	R6	pot., 200 $\Omega$	30013	T1	transformer, power
50002	J1	amphenol, male	10040	R7	res., 68 $\Omega$	90013	V1	12AU7 tube
52001	J2,3	binding post, 5 way	10018	R8,9	res., 22K $\Omega$ , 1/2 W, 20%	90022	V2	12AV7 tube
34501	L1	choke						

# MODEL 324 SIGNAL GENERATOR